

jura®



en

fr

es

pt

Instructions for use for IMPRESSA A9 One Touch



For your safety: read and understand manual before use.

Your IMPRESSA A9 One Touch

IMPORTANT SAFEGUARDS	4
Control elements	8
1 Preparing and using for the first time	10
JURA on the Internet	10
Touchscreen display	10
Setting up the machine	10
Filling the bean container	10
First-time use.....	11
First-time use with filter cartridge activation	11
First-time use without filter cartridge activation	12
Determining the water hardness	12
Connecting milk.....	13
Filling the water tank	14
2 Preparation	14
Ways of preparing a beverage.....	15
Ristretto, espresso and coffee	15
2 ristretti, 2 espressi and 2 coffees.....	15
Latte macchiato and Cappuccino	16
Latte macchiato doppio and Cappuccino doppio	16
Permanently setting the amount of water for the cup size.....	16
Ground coffee.....	16
Adjusting the grinder	17
Hot water.....	18
3 Daily operation	18
Switching on the machine	18
Daily maintenance.....	18
Regular maintenance.....	19
Switching off the machine	19
4 Permanent settings in programming mode	19
Replacing products on the start screen.....	19
Deactivating the start screen	19
Setting the water hardness	20
Automatic switch-off.....	20
Unit for amount of water	20
Language.....	21
5 Maintenance	21
Rinsing the machine	22
Rinsing the milk system	22
Cleaning the milk system.....	22
Dismantling and rinsing the dual spout.....	23
Inserting and activating the filter	24

Changing the filter.....	25
Cleaning the machine.....	26
Descaling the machine	27
Cleaning the bean container	28
Descaling the water tank.....	28
6 Display messages	29
7 Troubleshooting	30
8 Transport and environmentally friendly disposal	31
Transport / Emptying the system	31
Disposal	31
9 Technical data	31
10 Index	32
11 JURA contact details / Legal information	36

Symbol description

Warnings



This is the safety alert symbol. It is used to alert you to potential personal injury hazards. Obey all safety messages that follow this symbol to avoid possible injury or death.



DANGER indicates a hazardous situation which, if not avoided, will result in death or serious injury.



WARNING indicates a hazardous situation which, if not avoided, could result in death or serious injury.



CAUTION, used with the safety alert symbol, indicates a hazardous situation which, if not avoided, could result in minor or moderate injury.

NOTICE

NOTICE is used to address practices not related to personal injury.

Symbols used



Prompt to take action. This symbol means that you are being prompted to perform some action.



Information and tips to make it even easier to use your IMPRESSA.

'Coffee'

Display message

IMPORTANT SAFEGUARDS

Follow the basic safety precautions

When using electrical appliances, basic safety precautions shall always be followed, to reduce the risk of fire, electric shock, and/or injury to persons, including the following:

- Read all instructions.
- Do not touch hot surfaces. Use handles or knobs.
- To protect against fire, electric shock and injury to persons, do not immerse power cord, plugs, or body of machine in water or other liquid.
- Close supervision is necessary when any appliance is used by or near children.
- Unplug from outlet when not in use and before cleaning. Allow to cool before putting on or taking off parts, and before cleaning the appliance.
- Do not operate any appliance with a damaged cord or plug or after the appliance malfunctions, or has been damaged in any manner. Return appliance to the nearest authorized service facility for examination, repair or adjustment.
- The use of an accessory attachment not recommended by the appliance manufacturer may result in fire, electric shock, or injury to persons.
- Do not use outdoors.
- Do not let the cord hang over the edge of a table or counter, or touch hot surfaces.
- Do not place on or near a hot gas or electric burner, or in a heated oven.
- To disconnect, turn any control to 'OFF' then remove plug from wall outlet.
- Do not use appliance for other than intended use.
- Use extreme caution when dispensing hot steam, hot water or hot coffee.
- For household use only.

SAVE THESE INSTRUCTIONS.

Pass them on to any subsequent user.

Intended use The appliance is designed and intended for household use only. It shall only be used for coffee preparation, according to these instructions. Use for any other purpose will be deemed improper. JURA Elektroapparate AG cannot accept any responsibility for the consequences of improper use.

People, including children, who

- do not have the physical, sensory or mental capabilities to use the appliance safely or
- are inexperienced or lack knowledge in how to use the appliance safely

must be supervised by a responsible person when using it, or must be instructed in how to use it correctly.

Special power cord set instructions

- The power cord is provided to reduce the risk resulting from becoming entangled in or tripping over a long cord.
- The cord shall be arranged so that it will not drape over the counter top or table top where it can be pulled on by children or tripped over.
- This appliance has a 3-pin grounded plug.
- Do not modify the plug in any way.

Do NOT use extension cords.

If the user chooses to use an extension cord,

- the marked electrical rating of the extension cord shall be at least as great as the electrical rating of the appliance, and
- if the appliance is of the grounded type, the extension cord shall be a grounding type 3-wire cord, and
- the longer cord shall be arranged so that it will not drape over the counter top or tabletop where it can be pulled on by children or tripped over.

 **WARNING**



To reduce the risk of fire or electric shock, DO NOT remove any service covers. DO NOT modify the appliance in any way that is not described in these instructions. NO user serviceable parts included. Repair MUST be done by authorized personnel only.

In the event of signs of damage, for example if there is a smell of burning, unplug the machine immediately from outlet and contact JURA customer service.

IMPORTANT SAFEGUARDS

⚠ CAUTION

This appliance is for household use. Any servicing other than cleaning and user maintenance shall be performed by an authorized service representative:

- Do not immerse base in water or try to disassemble.
- Do not put the appliance or any individual parts in the dishwasher.
- Check voltage to be sure that the voltage indicated on the name plate complies with your voltage. The name plate is located on the underside of the appliance.
- Never use warm or hot water to fill the water container. Use cold water only.
- Keep your hands and the cord away from hot parts of the appliance during operation.

NOTICE

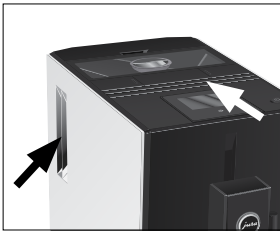

- Never clean with scouring powders or hard implements.
- Ensure that the ventilation slots are not covered.
- Never pull out the drip tray during the brewing process. Only pull the drip tray when the display instructs you or when the appliance is ready for use.

NEVER DO (or you will void your warranty protection):

- Never fill instant coffee, chocolate mix etc. into the bean container or ground coffee funnel (filler funnel for ground coffee). It will damage the functioning of the brewing chamber.
- Never fill sugar coated coffee beans into the bean container. In case of doubt, call your dealer.
- Never fill anything other than coffee beans into the bean container (no chocolate, no rice, no nuts, no spices, nothing other than roasted coffee beans).
- Never fill frozen beans into the bean container. If you store beans in the freezer, let them thaw 3 to 4 hours before filling them into the bean container.
- Never fill anything but fresh, cold and clean water into the water tank, except when decalcifying.
- Never use mineral or carbonated water. You can use tap water, bottled water, spring water and reverse osmosis water.
- Never do anything with the machine which is not described in these instructions. In case of doubt, call your dealer.

– intentionally blank –

Control elements

Control elements

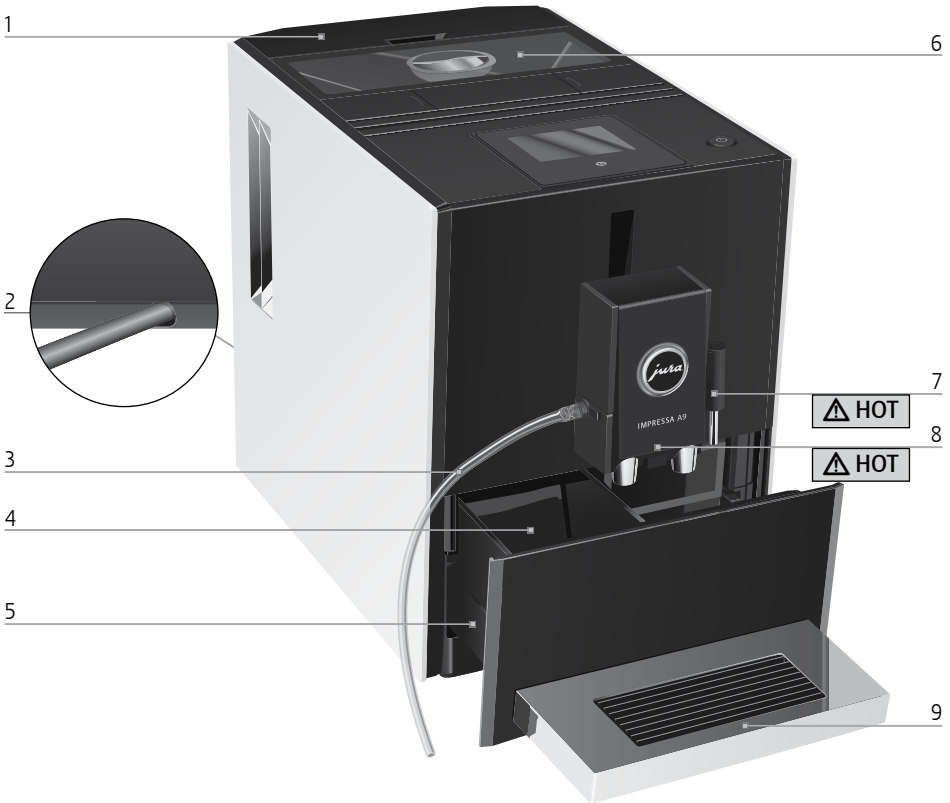

- 1 Water tank
- 2 Power cord (back of the machine)
- 3 Milk pipe
- 4 Coffee grounds container
- 5 Drip tray

- 6 Bean container with aroma preservation cover
- 7 Hot-water spout
- 8 Height-adjustable dual spout
- 9 Cup platform

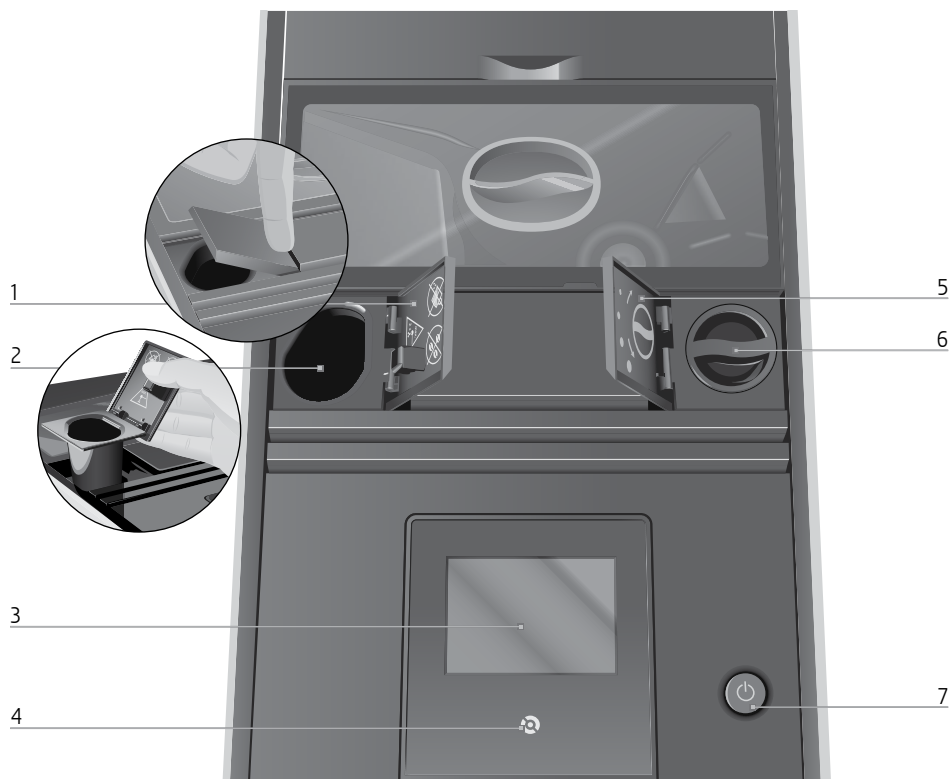

- 1 Cover for powder chute for ground coffee
- 2 Powder chute for ground coffee (removable)
- 3 Touchscreen display
- 4  Menu symbol

- 5 Cover cap for grinder adjustment switch
- 6 Grinder adjustment switch
- 7  On/Off button

1 Preparing and using for the first time

JURA on the Internet

Visit us on the Internet. You can download **short operating instructions** for your machine from the JURA website (www.jura.com). You will also find interesting and up-to-date information on your IMPRESSA and on every aspect of coffee.

Touchscreen display

Your IMPRESSA features an intuitive touchscreen display. There are two ways of operating the touchscreen display:

■ Touch

Touch the display with your finger, for example to start coffee preparation or undertake various settings in programming mode.

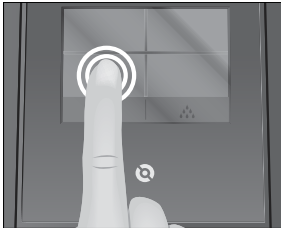

■ Slide

Move your finger from left to right (or vice versa) across the touchscreen display to select a specialty coffee in the product selector view.

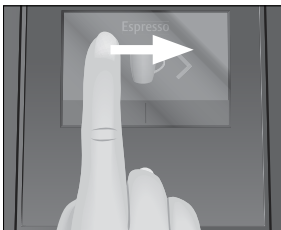

Setting up the machine

When setting up your IMPRESSA, please note the following:

- Place the IMPRESSA on a horizontal surface that is not sensitive to water.
- Choose a spot for your IMPRESSA which protects the machine against overheating. Ensure that the ventilation slots are not covered.

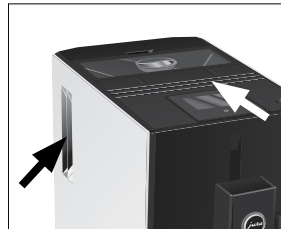

Filling the bean container

The bean container has an aroma preservation cover. This will ensure that your coffee beans retain their aroma for longer.

NOTICE

Coffee beans which have been treated with additives (e.g. sugar), ground coffee or freeze-dried coffee will damage the grinder.

- ▶ Only use untreated roasted coffee beans to refill the bean container.
- ▶ Remove the aroma preservation cover.
- ▶ Remove any dirt or foreign objects from inside the bean container.
- ▶ Fill the bean container with coffee beans and close the aroma preservation cover.

First-time use

When using the machine for the first time, you can choose whether you want to operate IMPRESSA **with** or **without** the CLEARLYL Blue filter cartridge. If the water hardness is 10 °dH or more, we recommend using the filter cartridge. If you do not know the hardness of your water, you can find this out first (see Chapter 1 'Preparing and using for the first time – Determining the water hardness').

⚠ WARNING

If the machine is operated with a defective power cord, there is a danger of potentially fatal electric shock.

- ▶ Never use a machine which is damaged.
- ▶ Never use a machine which has a defective power cord.

- i** The water volume is given as standard in 'oz'. You can change this setting to 'ml' in programming mode (see Chapter 4 'Permanent settings in programming mode – Unit for amount of water').

Precondition: The bean container has been filled.

- ▶ Insert the power plug into a power socket.
- ▶ Press the On/Off button  to switch the IMPRESSA on.

The display shows the languages you can choose from.

- i** To display more languages, touch '>' (bottom right).
- ▶ Touch the language you want, e.g. 'English'. 'Saved' appears briefly on the display to confirm the setting. 'Use filter', the box 'Inactive' lights up green.
- i** Now decide whether you want to operate your IMPRESSA **with** or **without** a CLEARLYL Blue filter cartridge.

First-time use with filter cartridge activation

NOTICE

Milk, sparkling mineral water or other liquids can damage the water tank or the machine.

- ▶ Only fill the water tank with fresh, cold water.

- ▶ Touch 'Active'.
- ▶ Touch 'Save'. 'Saved' appears briefly on the display. 'Insert filter'
- ▶ Remove the water tank.
- ▶ Open the filter holder and insert the filter cartridge into the water tank, exerting slight pressure.

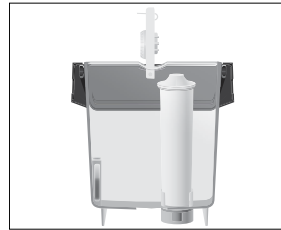

- ▶ Close the filter holder. It will click into place audibly.

- i** After three months, the filter will cease to work. Set the date on the date plate on the filter holder in the water tank.

- ▶ Fill the water tank with fresh, cold water and reinsert the tank.
- ▶ Place a receptacle (at least 10 oz or 300 ml) under the hot-water spout and the dual spout.



1 Preparing and using for the first time

- ▶ Touch **'Next'**.
'Filter is being rinsed', water flows out of the hot-water spout.

i The water may be slightly discolored. This is not harmful to health and does not affect the taste.

Rinsing of the filter stops automatically after approximately 10 oz (300 ml).

'Welcome to JURA'

'System is filling', the system fills up with water. Water flows out of the hot-water spout and the dual spout. The operation stops automatically.

'Machine is heating'

'Machine is rinsing', the machine rinses. The operation stops automatically. Your IMPRESSA is ready for use.

i The display shows the products you can prepare.

First-time use without filter cartridge activation

NOTICE

Milk, sparkling mineral water or other liquids can damage the water tank or the machine.

- ▶ Only fill the water tank with fresh, cold water.

- ▶ Touch **'Save'**.

'Saved' appears briefly on the display.

'Water hardness'

i If you do not know the hardness of your water, you must find this out first (see Chapter 1 'Preparing and using for the first time – Determining the water hardness').

- ▶ Touch **'<'** or **'>'** to adjust the water hardness.

- ▶ Touch **'Save'**.

'Saved' appears briefly on the display.

'Fill water tank'

- ▶ Remove the water tank and rinse it with cold water.

- ▶ Fill the water tank with fresh, cold water and reinsert the tank.

'Welcome to JURA'

'System is filling', the system fills up with water. Water flows out of the hot-water spout and the dual spout. The operation stops automatically.

'Machine is rinsing', the machine rinses.

The operation stops automatically. Your IMPRESSA is ready for use.

i The display shows the products you can prepare.

Determining the water hardness

You can find out what the water hardness is by using the Aquadur® test strip supplied as standard.

- ▶ Hold the test strip briefly (for 1 second) under flowing water. Shake off the water.
- ▶ Wait for about one minute.
- ▶ You will then be able to read the degree of water hardness from the discoloration of the Aquadur® test strip and the description on the packaging.

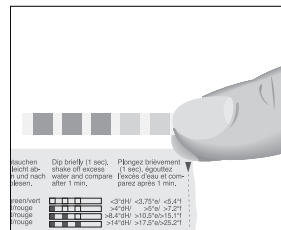

The water hardness can be adjusted on a continuous scale between 1 °dH and 30 °dH.

Level	Display German Degree (°dH)	Degrees of general hardness (°dGH)	Parts per million (ppm)	Indicator Strip number of 'reddish' fields
Not active	–	–	–	–
Very soft water	<3	<3	< 53.4	None
Soft water	> 4	> 4	> 71	1
Hard water	> 8.4	> 8.4	> 150	2
Very hard water	> 14	> 14	> 250	3

Connecting milk

Your IMPRESSA creates fine, creamy, feather-light milk foam with a perfect consistency. The most important requirement for frothing milk is a milk temperature of 39–46 °F (4–8 °C). We would therefore recommend using a milk cooler or a vacuum milk container.

- ▶ Remove the protective cover from the dual spout.

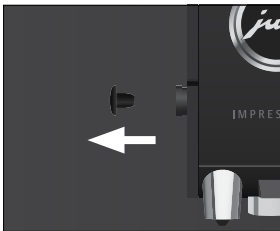

- ▶ Connect the milk pipe to the dual spout.

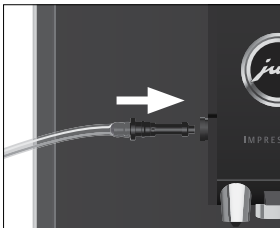

- ▶ Connect the other end of the milk pipe to a milk container or immerse it in a milk carton.

Filling the water tank

Daily maintenance of the machine and hygiene when handling milk, coffee and water are key to a perfect coffee result in the cup every time. You should therefore change the water **daily**.

NOTICE

Milk, sparkling mineral water or other liquids can damage the water tank or the machine.

- ▶ Only fill the water tank with fresh, cold water.
- ▶ Remove the water tank and rinse it with cold water.



- ▶ Fill the water tank with fresh, cold water and reinsert the tank.

2 Preparation

⚠ WARNING

Hot Coffee can cause scalding. Scalding is a serious burn.

- ▶ Use extreme care when handling hot liquid.
- ▶ Allow liquid to cool down before drinking.
- ▶ In the event of scalding, rinse affected area with cold water and seek medical attention.
- ▶ Keep children AWAY.

- i** You can stop preparation of a specialty coffee, specialty coffee with milk or hot water at any time. To do this, touch 'Cancel'.
- i** After a specialty coffee is selected and during grinding, the **coffee strength** is briefly displayed. You can change the coffee strength by touching the display ('<' or '>'). The next time you prepare this product, this coffee strength setting will be used.
- i** During preparation you can change the **amount of water** by touching '<' or '>'. This setting is not saved.
- i** You can follow the current status of preparation on the display.
- i** The water volume is given as standard in 'oz'. You can change this setting to 'ml' in programming mode (see Chapter 4 'Permanent settings in programming mode – Unit for amount of water').

Coffee tastes best served hot. A cold porcelain cup cools the beverage – and impairs the taste. We therefore recommend prewarming the cups. The full coffee aroma can develop only in prewarmed cups. You can purchase a JURA cup warmer from your specialized dealer.

Ways of preparing a beverage

The IMPRESSA offers various ways of preparing a speciality coffee, milk foam or hot water:

- **Preparation using the start screen:** Simply touch the desired product on the display (start screen).

The following products are displayed as standard on the start screen:

- 'Cappuccino'
- 'Latte macchiato'
- 'Espresso'
- 'Coffee'

- **Preparation using the product selector view:** Only some of the products you can prepare are shown on the start screen. As soon as you touch the '^ ^' box (bottom left), more products are displayed in a **product selector view**.

Move your finger from left to right (or vice versa) across the touchscreen display until the desired product is displayed. Then touch 'Prepare' to start preparation.

The following additional products are shown in the product selector view:

- 'Ristretto'
- '2 ristretti'
- '2 espressi'
- '2 coffees'
- 'Hot water'
- 'Milk foam'
- 'Latte macchiato doppio'
- 'Cappuccino doppio'

- i The product selector view disappears automatically after 10 seconds if no preparation is started.
- i You have the option of replacing the four products on the start screen with your personal favourites (see Chapter 4 'Permanent settings in programming mode – Replacing products on the start screen'). Please note that the descriptions provided in the following sections always refer to the default settings.

Ristretto, espresso and coffee

Example: Proceed as follows to prepare one coffee.

Precondition: The start screen is displayed.

- ▶ Place a cup under the coffee spout.
- ▶ Touch 'Coffee'.
Preparation starts. The preset amount of water for coffee flows into the cup.
Preparation stops automatically. Your IMPRESSA is once more ready for use.

2 ristretti, 2 espressi and 2 coffees

There are several ways of preparing **two** speciality coffees.

- When preparing a single product:
 - As soon as you start preparing a single product, '2x' is displayed in the bottom right of the display. Touch '2x' to prepare the double product.
- Using the **product selector view**:
 - In the product selector view, move your finger from left to right (or vice versa) across the touchscreen display until the required double product '2 ristretti', '2 espressi' or '2 coffees' is displayed. Then touch 'Prepare'.

Example: Proceed as follows to prepare **two coffees** (using product selector view).

Precondition: The start screen is displayed.

- ▶ Place two cups under the coffee spout.
- ▶ Touch the '^ ^' box (bottom left).
- ▶ Move your finger from left to right (or vice versa) across the touchscreen display until '2 coffees' is displayed.
- ▶ Touch 'Prepare'.
Coffee preparation starts.

- i Please note that when two speciality coffees are prepared, the second is prepared immediately after the first.

The preset amount of water for coffee flows into the cups. Preparation stops automatically. Your IMPRESSA is once more ready for use.

Latte macchiato and Cappuccino

Your IMPRESSA can prepare a latte macchiato or cappuccino at the touch of a button. There is no need to move the glass or cup.

Example: Proceed as follows to prepare one latte macchiato.

Precondition: The start screen is displayed. Milk is connected to the dual spout.

- ▶ Place a glass under the dual spout.
- ▶ Touch **'Latte macchiato'**.
'Latte macchiato', the milk foam is prepared. Preparation stops automatically when the preset amount of milk is reached.

i There is a short interval while the hot milk separates from the milk foam. This allows the typical layers of a latte macchiato to form.

Coffee preparation starts. The preset amount of water flows into the glass. Preparation stops automatically. Your IMPRESSA is once more ready for use.

To make sure the dual spout always works properly, you must rinse and clean it regularly (see Chapter 5 'Maintenance – Cleaning the milk system').

Latte macchiato doppio and Cappuccino doppio

'Doppio' is Italian for 'double'. When you prepare a latte macchiato doppio or a cappuccino doppio, **two espressi** are dispensed one after the other directly into the hot milk foam. The result is an extra full-bodied and aromatic specialty coffee.

The amount of water and milk foam used for a latte macchiato doppio and cappuccino doppio cannot be changed. The amount of milk foam is the same as for a 'standard' latte macchiato or cappuccino. The two espressi are prepared with half the amount of water programmed for latte macchiato and cappuccino.

Permanently setting the amount of water for the cup size

It is easy to permanently adjust the amount of water for all single products and hot water according to the cup size. Adjust the amount once as shown in the following example. Every time you prepare a drink in the future, this amount will be dispensed.

The permanent settings for adapting the amount of water to the cup size for all specialty coffees and hot water follow this model.

Example: Proceed as follows to **permanently** set the amount of water for one coffee.

Precondition: The start screen is displayed.

- ▶ Place a cup under the coffee spout.
- ▶ Touch the **'Coffee'** box for **about 2 seconds** until **'Enough coffee?'** appears. Preparation starts and the coffee flows into the cup.
- ▶ Touch **'Save'** as soon as there is sufficient coffee in the cup. Preparation stops. **'Saved'** appears briefly on the display. The set amount of water for one coffee is permanently stored. Your IMPRESSA is once more ready for use.

i You can alter this setting at any time by repeating the above procedure.

i The amount can be permanently adjusted to the cup size for the products shown in the **product selector view** too. Move your finger across the display until the desired product is displayed. Then touch **'Prepare'** for **about 2 seconds** until **'Enough coffee?'** appears.

Ground coffee

You can choose to use a second coffee variety, for example decaffeinated coffee, with the filter funnel for ground coffee.

i Never add more than one level measuring spoon of ground coffee.

- i** It is not possible to prepare two ristretti, two espressi or two coffees with ground coffee.
- i** Use ground coffee which is not ground too finely. Very fine coffee can block up the system so that the coffee only comes out in drips.
- i** If you did not fill the machine with a sufficient amount of ground coffee, 'Not enough ground coffee' is displayed and the IMPRESSA stops the operation.
- i** The desired specialty coffee must be prepared within approximately one minute after filling with the ground coffee. Otherwise the IMPRESSA stops the operation and is once more ready for use.

Example: Proceed as follows to prepare one espresso using ground coffee.

- ▶ Place an espresso cup under the coffee spout.
- ▶ Open the powder chute cover. 'Please add ground coffee'
- ▶ Fit the filler funnel for ground coffee on the powder chute.

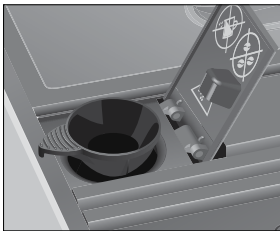

- ▶ Place one level measuring spoon of ground coffee into the filler funnel.
- ▶ Close the cover of the powder chute. The start screen is displayed.
- ▶ Touch 'Espresso'. Preparation starts. The preset amount of water for espresso flows into the cup. Preparation stops automatically. Your IMPRESSA is once more ready for use.

Adjusting the grinder

You can adjust the grinder on a continuous scale to suit the degree of roast of your coffee.

NOTICE

If you adjust the consistency of grind when the grinder is not operating, the grinder adjustment switch could be damaged.

- ▶ Only adjust the consistency of grind when the grinder is running.

The consistency of grind is correct if the coffee flows regularly from the coffee spout. In addition a fine, thick crema forms.

Example: Proceed as follows to change the consistency of grind **during** the preparation of an espresso.

- ▶ Place a cup under the coffee spout.
- ▶ Open the cover of the grinder adjustment switch.
- ▶ Touch 'Espresso'. The coffee strength is briefly displayed. The grinder starts up.
- ▶ Turn the grinder adjustment switch to the desired position **while** the grinder is running.



The espresso is prepared and the consistency of grind is adjusted.

- ▶ Close the cover of the grinder adjustment switch.
- i** Please note that the new consistency of grind only takes effect when the second beverage is prepared.

3 Daily operation

Hot water

CAUTION

There is a danger of scalding from hot water splashes.

- ▶ Avoid direct contact with the skin.
- ▶ Place a cup under the hot-water spout.



- ▶ Touch ‘^’ (bottom left) to go to the product selector view.
- ▶ Move your finger from left to right (or vice versa) across the touchscreen display until ‘Hot water’ is displayed.
- ▶ Touch ‘Prepare’.
‘Hot water’, hot water flows into the cup. Preparation stops automatically. Your IMPRESSA is once more ready for use.

3 Daily operation

Switching on the machine

Daily maintenance of the machine and hygiene when handling milk, coffee and water are key to a perfect coffee result in the cup every time. You should therefore change the water **daily**.

- ▶ Place a receptacle under the dual spout.



- ▶ Press the On/Off button  to switch the IMPRESSA on.
‘Welcome to JURA’
‘Machine is heating’
‘Machine is rinsing’, the system rinses itself. The operation stops automatically. Your IMPRESSA is ready for use.

Daily maintenance

To ensure that you get many years of reliable service out of your IMPRESSA and to guarantee the optimum coffee quality, the machine requires daily maintenance.

- ▶ Pull out the drip tray.



- ▶ Empty the coffee grounds container and the drip tray. Rinse them both with warm water.

i Always empty the coffee grounds container when the machine is **switched on**. This is the only way of resetting the coffee grounds counter.

- ▶ Refit the coffee grounds container and the drip tray.
- ▶ Rinse the water tank with clean water.
- ▶ Remove the milk pipe and rinse it thoroughly under running water.
- ▶ Dismantle and rinse the dual spout (see Chapter 5 ‘Maintenance – Dismantling and rinsing the dual spout’).
- ▶ Wipe the surface of the machine with a clean, soft, damp cloth (e.g. microfiber cloth).

Regular maintenance

Carry out the following maintenance actions **regularly or as required**:

- In the interests of hygiene, we recommend changing the milk pipe on a regular basis (approximately every 3 months). Replacement pipes are available from specialized dealers (JURA original accessory set for frothers).
- Clean the inside of the water tank, e.g. with a brush. Further information about the water tank is provided in these instructions for use (see Chapter 5 'Maintenance – Descaling the water tank').
- Traces of milk and coffee may stick to the top and bottom of the cup platform. If this happens, clean the cup platform.

Switching off the machine

When the IMPRESSA is switched off, the system is automatically rinsed if a specialty coffee has been prepared. If milk has been prepared, the milk system is rinsed too.

- ▶ Place a receptacle under the dual spout.



- ▶ Press the On/Off button . 'Machine is rinsing', 'Milk system is being rinsed', the system rinses itself. The operation stops automatically. Your IMPRESSA is switched off.
- i** Empty the water tank after switching off.
- i** When the IMPRESSA is switched off with the On/Off button, the machine does **not consume standby energy**.

4 Permanent settings in programming mode

Touch the Menu symbol  for about 2 seconds to view the list of maintenance programs and switch to programming mode. The following settings can be made:

- Deactivate start screen
- Water hardness
- Units
- Automatic switch-off
- Language

You can also add your four favourite products to the start screen (see next chapter).

Replacing products on the start screen

You have the option of replacing the four products on the start screen with your personal favourites.

Example: Proceed as follows to replace 'Latte macchiato' on the start screen with 'Latte macchiato doppio'.

Precondition: The start screen is displayed.

- ▶ Touch '▲' for **about 2 seconds** until 'Replace which product?' appears in the bottom right.
- ▶ Touch 'Latte macchiato'.
The product selector view is launched.
- ▶ Move your finger from left to right (or vice versa) across the touchscreen display until 'Latte macchiato doppio' is displayed.
- ▶ Touch 'Save'.
'Saved' appears briefly on the display. 'Latte Mac. Doppio' is displayed in the selected position on the start screen.

Deactivating the start screen

You can deactivate the start screen so that the **product selector view** is displayed as standard.



- 'Start screen' / 'Active'
 - The start screen is displayed. You can go to the product selector view by touching the 'Rotary Selection' box.

4 Permanent settings in programming mode

- **'Start screen' / 'Inactive'**
 - The start screen is deactivated. The **product selector view** is displayed as standard.

Example: Proceed as follows to deactivate the start screen.

Precondition: The start screen is displayed.

- ▶ Touch the Menu symbol  for **about 2 seconds**.
- ▶ Touch '**>**' (bottom right) several times until the program item **'Start screen'** is displayed.
- ▶ Touch **'Start screen'**.
- ▶ Touch **'Inactive'**.
- ▶ Touch **'Save'**.
'Saved' appears briefly on the display.
- ▶ Touch the Menu symbol  to exit programming mode.
The product selector view is displayed.

Setting the water hardness

- i** If you are using the CLEARLY Blue filter cartridge and have activated it, it is not possible to set the water hardness.

The harder the water is, the more frequently the IMPRESSA needs to be descaled. It is therefore important to set the water hardness accurately.

The water hardness can be adjusted on a continuous scale between 1 °dH and 30 °dH.

Precondition: The start screen is displayed.

- ▶ Touch the Menu symbol  for **about 2 seconds**.
- ▶ Touch '**>**' (bottom right).
- ▶ Touch '**>**' several times until **'Water hardness'** is displayed.
- ▶ Touch **'Water hardness'**.
'Water hardness'
- ▶ Touch '**<**' or '**>**' to adjust the water hardness.
- ▶ Touch **'Save'**.
'Saved' appears briefly on the display.



- ▶ Touch the Menu symbol  to exit programming mode.
The start screen is displayed.

Automatic switch-off

By instructing your IMPRESSA to automatically switch itself off, you can cut down your energy consumption. Your IMPRESSA switches off automatically after the preset time following the last action on the machine.

You can set the automatic switch-off to 15 minutes, 30 minutes or 1–15 hours.

Precondition: The start screen is displayed.

- ▶ Touch the Menu symbol  for **about 2 seconds**.
- ▶ Touch '**>**' (bottom right).
- ▶ Touch '**>**' several times until **'Switch off after'** is displayed.
- ▶ Touch **'Switch off after'**.
'Switch off after'
- ▶ Touch '**<**' or '**>**' to change the setting.
- ▶ Touch **'Save'**.
'Saved' appears briefly on the display.
- ▶ Touch the Menu symbol  to exit programming mode.
The start screen is displayed.

Unit for amount of water

You can change the unit for the amount of water from 'ml' to 'oz'.

Precondition: The start screen is displayed.

- ▶ Touch the Menu symbol  for **about 2 seconds**.
- ▶ Touch '**>**' (bottom right).
- ▶ Touch '**>**' several times until **'Units'** is displayed.
- ▶ Touch **'Units'**.
'Units'
- ▶ Touch **'ml'** or **'oz'** to select the unit for the amount of water.

- ▶ Touch 'Save'.
'Saved' appears briefly on the display.
- ▶ Touch the Menu symbol  to exit programming mode.
The start screen is displayed.

Language

In this program item you can set the language used by your IMPRESSA.

Example: Proceed as follows to change the language from 'English' to 'Deutsch'.

Precondition: The start screen is displayed.

- ▶ Touch the Menu symbol  for **about 2 seconds**.
- ▶ Touch '>' (bottom right).
- ▶ Touch '>' several times until 'Choose language' is displayed.
- ▶ Touch 'Choose language'.

- i** To display more languages, touch '>' (bottom right).
- ▶ Touch 'Deutsch'.
'Gespeichert' appears briefly on the display.
- ▶ Touch the Menu symbol  to exit programming mode.
The start screen is displayed.

5 Maintenance

WARNING

Use of maintenance products that are harmful to health and discharge of liquids during maintenance program. Harmful if swallowed. Irritating to eyes and skin.

- ▶ Keep children AWAY.
- ▶ Keep children away from the machine while it is performing a maintenance program.
- ▶ Avoid contact with skin and eyes.
- ▶ Avoid generation of dust. Do not inhale dust.
- ▶ When using do not eat or drink.
- ▶ Keep maintenance products away from food, drink and animal food.
- ▶ Keep container tightly closed and dry. Keep in a cool place.

Your IMPRESSA has the following integrated maintenance programs:

- Rinsing the machine ('Rinse the coffee system')
 - Rinsing the milk system in the dual spout ('Rinse the milk system')
 - Cleaning the milk system in the dual spout ('Clean the milk system')
 - Changing the filter ('Change the filter') (only if filter is activated)
 - Cleaning the machine ('Clean')
 - Descaling the machine ('Descal') (only if filter is not activated)
- i** Clean or descale the machine, rinse the milk system or change the filter when you are prompted to do so.
 - i** Touch the Menu symbol  for about 2 seconds to view the list of maintenance programs. By referring to the bar you can see which maintenance program is due. When the bar is completely filled with red, your IMPRESSA will prompt you to perform the appropriate maintenance program.
 - i** In the interests of hygiene, you should clean the milk system **daily** when you have been preparing milk.

Rinsing the machine

You can initiate the rinse operation manually at any time.

Precondition: The start screen is displayed.

- ▶ Place a receptacle under the dual spout.



- ▶ Touch '☼'.
- ▶ Touch 'Rinse the coffee system'. 'Machine is rinsing', water flows out of the dual spout. The rinse stops automatically. Your IMPRESSA is once more ready for use.

Rinsing the milk system

After milk preparation, the IMPRESSA prompts you to rinse the milk system.

Precondition: 'Rinse the milk system' is displayed.

- ▶ Place a receptacle under the dual spout.



- ▶ Touch 'Rinse the milk system'. 'Milk system is being rinsed', water flows out of the dual spout. The rinse stops automatically. Your IMPRESSA is once more ready for use.

Cleaning the milk system

To ensure that the milk system in the dual spout always works properly, you must clean it **daily** when you have been preparing milk.

⚠ WARNING

Non-recommended cleaning agents will not optimally remove milk residues. This may cause the cappuccino frother to become blocked and fly off the machine. Discharge of hot steam.

- ▶ Use only original JURA milk system cleaner.

⚠ WARNING

Harmful and irritating cleaning agent. Harmful if swallowed. Irritating to eyes and skin.

- ▶ Keep children AWAY.
- ▶ Avoid contact with skin and eyes.
- ▶ After contact with skin, wash immediately with plenty of water. In case of skin irritation, seek medical advice.
- ▶ After eye contact, immediately flush eyes with plenty of water and seek medical advice.
- ▶ If swallowed, rinse mouth immediately and drink large quantities of water. Do not induce vomiting. Seek medical advice immediately and show label.

i JURA milk system cleaner is available from specialized dealers.

Precondition: The start screen is displayed.

- ▶ Touch the Menu symbol  for **about 2 seconds**.
- ▶ Touch 'Clean the milk system'. 'Clean the milk system'
- ▶ Touch 'Start'.
- ▶ Touch 'Start' again. 'Milk system cleaner'
- ▶ Pour 8.5 oz (250 ml) of fresh water into a receptacle and add one capful of milk system cleaner.
- ▶ Immerse the milk pipe in the receptacle.

- ▶ Place another receptacle under the dual spout.



- ▶ Touch **'Next'**.
'Cleaning milk system', the dual spout and the pipe are cleaned.
'Fresh water'
- ▶ Rinse the receptacle thoroughly, fill it with 8.5 oz (250 ml) of fresh water and immerse the milk pipe in the water.
- ▶ Empty the other receptacle and place it under the dual spout again.



- ▶ Touch **'Next'**.
'Cleaning milk system', the dual spout and the pipe are rinsed with fresh water. The operation stops automatically. **'Milk system cleaning complete'** appears briefly on the display. Your IMPRESSA is once more ready for use.

Dismantling and rinsing the dual spout

The dual spout must be dismantled and rinsed **daily** if milk has been prepared to make sure it functions perfectly and also in the interests of hygiene.

- ▶ Remove the milk pipe and rinse it thoroughly under running water.

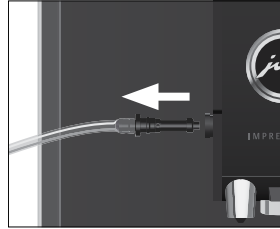

- ▶ Press the releasing devices and pull the dual spout down and off.

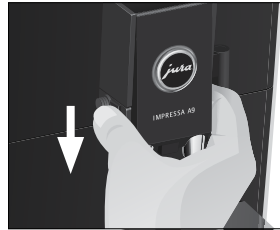

- ▶ Press the milk system down and take it out.

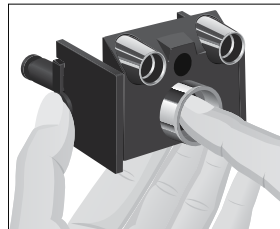

- ▶ Dismantle the milk system into its individual parts.

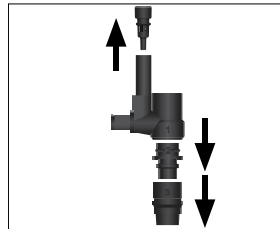

- ▶ Rinse all the parts under running water. If there are severely dried-on milk residues,

5 Maintenance

immerse the individual parts in a solution of 8.5 oz (250 ml) cold water and 1 capful of JURA milk system cleaner. Then rinse the parts thoroughly.

- ▶ Fit the air intake pipe.

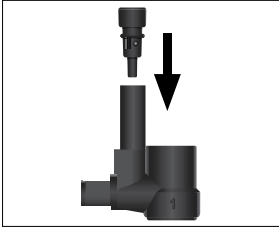

- ▶ Reassemble the milk system. When doing this, note the numbering of the individual parts.

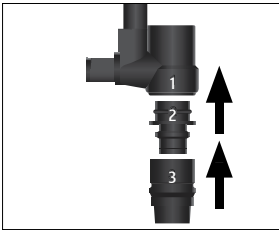

- ▶ Fit the assembled individual parts back in the dual spout and press it firmly.
- ▶ Fit the dual spout on the machine. It will click into place audibly.



Inserting and activating the filter

Your IMPRESSA no longer has to be descaled if you are using the CLEARYL Blue filter cartridge. If the water hardness is 10 °dH or more, we recommend using the filter cartridge. If you do not know the

hardness of your water, you can find this out first (see Chapter 1 'Preparing and using for the first time – Determining the water hardness').

If you did not activate the filter cartridge the first time you used the machine, you can do this now as follows.

- i** Perform the 'inserting the filter' operation without any interruptions. This will ensure that your IMPRESSA always produces its best.

Precondition: The start screen is displayed.

- ▶ Touch the Menu symbol  for **about 2 seconds**.
- ▶ Touch '>' (bottom right) several times until the program item '3/4' is displayed.
- ▶ Touch 'Use filter'.
- ▶ Touch 'Active'.
- ▶ Touch 'Save'.
- ▶ 'Saved' appears briefly on the display.
- ▶ 'Insert filter'
- ▶ Remove the water tank.
- ▶ Open the filter holder and insert the filter cartridge into the water tank, exerting slight pressure.

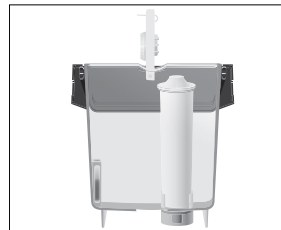

- ▶ Close the filter holder. It will click into place audibly.
- i** After three months, the filter will cease to work. Set the date on the date plate on the filter holder in the water tank.
- ▶ Fill the water tank with fresh, cold water and reinsert the tank.

- ▶ Place a receptacle (at least 10 oz or 300 ml) under the hot-water spout.



- ▶ Touch 'Next'.
'Filter is being rinsed', water flows out of the hot-water spout.

i The water may be slightly discolored. This is not harmful to health and does not affect the taste.

Rinsing of the filter stops automatically after approximately 10 oz (300 ml).

'Machine is heating'

Your IMPRESSA is once more ready for use.

Changing the filter

- i** After 2000 oz (60 liters) of water have flowed through, the filter will cease to work. Your IMPRESSA will automatically prompt you to change the filter.
- i** After three months, the filter will cease to work. Set the date on the date plate on the filter holder in the water tank.
- i** If the CLEARYL Blue filter cartridge is not activated in programming mode, you will not be prompted to change the filter.

Precondition: The start screen is displayed. The box with the Maintenance symbol ☸ lights up red.

- ▶ Touch '☸'.
- ▶ Touch 'Change the filter'.
'Change the filter'

i If you do not want to start changing the filter just yet, press the '⏮' button.

- ▶ Touch 'Start'.

- ▶ Touch 'Start' again.
'Change the filter'
- ▶ Remove and empty the water tank.
- ▶ Open the filter holder and remove the old CLEARYL Blue filter cartridge.
- ▶ Insert a **new** CLEARYL Blue filter cartridge into the water tank, exerting slight pressure.

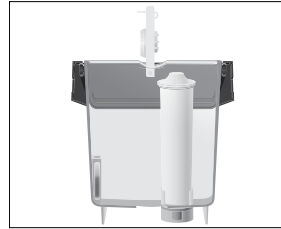

- ▶ Close the filter holder. It will click into place audibly.

i After three months, the filter will cease to work. Set the date on the date plate on the filter holder in the water tank.

- ▶ Fill the water tank with fresh, cold water and reinsert the tank.
- ▶ Place a receptacle (at least 10 oz or 300 ml) under the hot-water spout.



- ▶ Touch 'Next'.
'Filter is being rinsed', water flows out of the hot-water spout.

i The water may be slightly discolored. This is not harmful to health and does not affect the taste.

Rinsing of the filter stops automatically after approximately 10 oz (300 ml).

'Machine is heating'

Your IMPRESSA is once more ready for use.

Cleaning the machine

After 180 preparations or 80 switch-on rinses, the IMPRESSA will prompt you to clean it.

⚠ WARNING

Non-recommended (e.g. liquid) cleaning agents may contain substances that could damage the machine or leave residues.

- ▶ Use only original JURA cleaning tablets. These are specially formulated for your machine.

⚠ WARNING

Harmful and irritating cleaning agent. Harmful if swallowed. Irritating to eyes and skin.

- ▶ Keep children AWAY.
- ▶ Avoid contact with skin and eyes.
- ▶ Avoid generation of dust. Do not inhale dust.
- ▶ After contact with skin, wash immediately with plenty of water. In case of skin irritation, seek medical advice.
- ▶ After eye contact, immediately flush eyes with plenty of water and seek medical advice.
- ▶ If swallowed, rinse mouth immediately and drink large quantities of water. Do not induce vomiting. Seek medical advice immediately and show label.

- i** The cleaning program lasts approximately 20 minutes.
- i** Do not interrupt the cleaning program. The quality of cleaning will be impaired if you do so.
- i** JURA cleaning tablets are available from specialized dealers.

Precondition: The start screen is displayed. The box with the Maintenance symbol  lights up red.

- ▶ Touch .
- ▶ Touch 'Clean'.
'Clean'

- i** If you do not want to start cleaning just yet, press the '' button.

- ▶ Touch 'Start'.
- ▶ Touch 'Start' again.
'Empty grounds'
- ▶ Empty the drip tray and coffee grounds container and put them back into the machine.
'Press the menu button'
- ▶ Touch the Menu symbol .
'Machine is being cleaned'
The operation is interrupted, 'Add cleaning tablet'.
- ▶ Open the cover of the filler funnel for ground coffee.
- ▶ Insert a JURA cleaning tablet into the filler funnel.

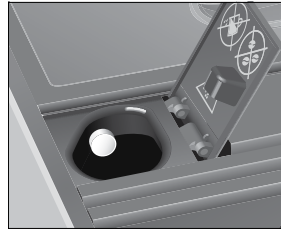

- ▶ Close the cover of the filler funnel.
'Press the menu button'
- ▶ Touch the Menu symbol .
'Machine is being cleaned'
'Empty grounds'
- ▶ Empty the drip tray and coffee grounds container and put them back into the machine.
Cleaning is now complete. Your IMPRESSA is once more ready for use.

Descaling the machine

The IMPRESSA builds up deposits of limescale over time and automatically prompts you to descale it when necessary. The degree of calcification depends on the hardness of your water.

⚠ WARNING

Non-recommended descaling agents (e.g. vinegar) may contain substances that could damage the machine or leave residues.

- ▶ Use only original JURA descaling tablets. These are specially formulated for your machine.

⚠ WARNING

Harmful and irritating descaling agent. Harmful if swallowed. Irritating to eyes and skin.

- ▶ Keep children AWAY.
- ▶ Avoid contact with skin and eyes.
- ▶ Avoid generation of dust. Do not inhale dust.
- ▶ After contact with skin, wash immediately with plenty of water. In case of skin irritation, seek medical advice.
- ▶ After eye contact, immediately flush eyes with plenty of water. Remove contact lenses. Seek medical advice.
- ▶ If swallowed, rinse mouth immediately and drink large quantities of water. Do not induce vomiting. Seek medical advice immediately and show label.

NOTICE

If the descaling operation is interrupted, there may be damage to the machine.

- ▶ Allow the descaling program to run to the end.

- i** The descaling program lasts approximately 45 minutes.
- i** JURA descaling tablets are available from specialized dealers.
- i** If you use a CLEARYL Blue filter cartridge and this is activated, you will not be prompted to descale.

- i** If the descaling agent comes into contact with sensitive surfaces (e.g. marble), damage cannot be ruled out. Clean up any splashes immediately.

Precondition: The start screen is displayed. The box with the Maintenance symbol ☼ lights up red.

- ▶ Touch '☼'.
- ▶ Touch 'Descale'.
- ▶ Touch 'Descale'.

- i** If you do not want to start descaling just yet, press the 'L' button.

- ▶ Touch 'Start'.
- ▶ Touch 'Start' again.
- ▶ Empty the drip tray and coffee grounds container and put them back into the machine.
- ▶ 'Agent in tank'
- ▶ Place a receptacle under the hot-water spout.



- ▶ Remove and empty the water tank.
- ▶ Completely dissolve 3 JURA descaling tablets in a receptacle holding 17 oz (500 ml) of water. This may take several minutes.

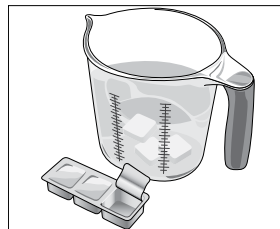

5 Maintenance

- ▶ Pour the solution into the empty water tank and insert it into the machine.
'Press the menu button'
- ▶ Touch the Menu symbol .
'Machine is being descaled', water flows out of the hot-water nozzle repeatedly.
The operation is interrupted, 'Empty drip tray'.
- ▶ Empty the receptacle.
- ▶ Empty the drip tray and coffee grounds container and put them back into the machine.
'Fill water tank'
- ▶ Place a receptacle under the dual spout and the hot-water spout.



- ▶ Remove the water tank and rinse it thoroughly.
- ▶ Fill the water tank with fresh, cold water and reinsert the tank.
'Press the menu button'
- ▶ Touch the Menu symbol .
'Machine is being descaled', water flows out of the dual and hot-water spout.
'Machine is rinsing', water flows out of the dual spout.
The operation stops automatically, 'Empty drip tray'.
- ▶ Empty the drip tray and coffee grounds container and put them back into the machine.
Descaling is now complete. Your IMPRESSA is once more ready for use.

i If the descaling operation stops unexpectedly, rinse the water tank thoroughly.

Cleaning the bean container

Coffee beans may be covered with a slight oil film which remains on the walls of the bean container. These traces may negatively affect the coffee result. For this reason clean the bean container from time to time.

Precondition: 'Fill bean container' is displayed.

- ▶ Switch the machine off with the On/Off button .
- ▶ Remove the aroma preservation cover.
- ▶ Clean the bean container with a soft, dry cloth.
- ▶ Fill the bean container with coffee beans and close the aroma preservation cover.

Descaling the water tank

Limescale deposits may form in the water tank. To ensure correct function of the machine, descale the water tank from time to time.

- ▶ Remove the water tank.
- ▶ If you use a CLEARYL Blue filter cartridge, remove this.
- ▶ Completely fill the water tank and dissolve 3 JURA descaling tablets in it.
- ▶ Leave the water tank with the descaling solution for several hours (e.g. overnight).
- ▶ Empty the water tank and rinse it thoroughly.
- ▶ If you use a CLEARYL Blue filter cartridge, insert this again.
- ▶ Fill the water tank with fresh, cold water and reinsert the tank.

6 Display messages

Message	Cause/Result	Action
'Fill water tank'	The water tank is empty. You cannot prepare any products.	▶ Fill the water tank (see Chapter 1 'Preparing and using for the first time – Filling the water tank').
'Empty grounds'	The coffee grounds container is full. You cannot prepare any products.	▶ Empty the coffee grounds container and the drip tray (see Chapter 3 'Daily operation – Daily maintenance').
'Empty drip tray'	The drip tray is full. You cannot prepare any products.	▶ Empty the coffee grounds container and the drip tray (see Chapter 3 'Daily operation – Daily maintenance').
'Tray missing'	The drip tray and coffee grounds container are not fitted correctly or not fitted at all. You cannot prepare any products.	▶ Fit the coffee grounds container and the drip tray.
'Fill bean container'	The bean container is empty. You cannot prepare any products.	▶ Fill the bean container (see Chapter 1 'Preparing and using for the first time – Filling the bean container').
'Beancover is not fitted'	The aroma preservation cover for the bean container is not fitted or not fitted correctly.	▶ Fit the aroma preservation cover correctly.
'Rinse the milk system', the box with the Maintenance symbol ☼ lights up red.	The IMPRESSA is prompting you to rinse the milk system.	Touch the box with the Maintenance symbol ☼ to start rinsing the milk system.
The box with the Maintenance symbol ☼ lights up red.	The IMPRESSA is prompting you to perform a maintenance program.	Touch the box with the Maintenance symbol ☼ to view the list of maintenance programs. By referring to the bar you can see which maintenance program is due. When the bar is completely filled with red, your IMPRESSA will prompt you to perform the appropriate maintenance program.
'Not enough ground coffee'	There is insufficient ground coffee in the machine; the IMPRESSA stops the operation.	▶ The next time you prepare a beverage, add more ground coffee (see Chapter 2 'Preparation – Ground coffee').
'Too hot'	The system is too hot to start a maintenance program.	Wait a few minutes until the system has cooled down.

7 Troubleshooting

Problem	Cause/Result	Action
Insufficient foam is produced when the milk is frothed, or milk sprays from the dual spout.	The dual spout is dirty.	<ul style="list-style-type: none"> ▶ Clean the milk system in the dual spout (see Chapter 5 'Maintenance – Cleaning the milk system'). ▶ Dismantle and rinse the dual spout (see Chapter 5 'Maintenance – Dismantling and rinsing the dual spout').
Coffee only comes out in drips when it is being prepared.	Coffee or ground coffee has been ground too finely and is blocking the system. The same filter cartridge may have been used several times or the water hardness set incorrectly in the programming mode.	<ul style="list-style-type: none"> ▶ Put the grinder on a coarser setting or use coarser ground coffee (see Chapter 2 'Preparation – Adjusting the grinder'). ▶ Perform descaling (see Chapter 5 'Maintenance – Descaling the machine').
Water hardness cannot be adjusted.	The CLEARYL Blue filter cartridge is activated.	<ul style="list-style-type: none"> ▶ Deactivate the filter cartridge in programming mode.
'Fill water tank' is displayed although the water tank is full.	The water tank float is trapped.	<ul style="list-style-type: none"> ▶ Descale the water tank (see Chapter 5 'Maintenance – Descaling the water tank').
Grinder is making a very loud noise.	There are foreign objects in the grinder.	<ul style="list-style-type: none"> ▶ Contact customer support in your country (see Chapter 11 'JURA contact details / Legal information').
'ERROR 2' or 'ERROR 5' is displayed.	If the machine was exposed to the cold for a long period of time, heating is disabled for safety reasons.	<ul style="list-style-type: none"> ▶ Warm the machine at room temperature.
Other 'ERROR' messages are displayed.	–	<ul style="list-style-type: none"> ▶ Contact customer support in your country (see Chapter 11 'JURA contact details / Legal information').

i If you were unable to solve the problem, contact customer support in your country (see Chapter 11 'JURA contact details / Legal information').

8 Transport and environmentally friendly disposal

Transport / Emptying the system

In order to protect the IMPRESSA from frost during transport, the system must be emptied.

Precondition: The start screen is displayed.

- ▶ Touch the 'Rotary Selection' box.
The product selector view is launched.
- ▶ Move your finger from left to right (or vice versa) across the touchscreen display until 'Hot water' is displayed.
- ▶ Touch 'Prepare'.
'Hot water', water flows out of the hot-water spout.
- ▶ Remove and empty the water tank.
Water will flow out of the hot-water spout until the system is empty.
'Fill water tank'
- ▶ Switch the machine off with the On/Off button .
Your IMPRESSA is switched off.

Disposal

Please dispose of old machines in an environmentally neutral way.



9 Technical data

Voltage	120 V ~, 60 Hz
Power	1450 W
Conformity mark	
Pump pressure	static, max. 15 bar
Holding capacity of water tank (without filter)	37.2 oz (1.1 l)
Holding capacity of bean container	4.4 oz (125 g)
Holding capacity of coffee grounds container	Approx. 10 servings
Cord length	approx. 43.3 in. (approx. 1.1 m)
Weight	approx. 24 lb (approx. 10.9 kg)
Dimensions (W × H × D)	9.4 × 12.7 × 17.5 in. (23.9 × 32.3 × 44.5 cm)

Information for testers (repeat test in accordance with DIN VDE 0701-0702): The central grounding point (CGP) is located on the underside of the machine, on the right and at the back.

Directives

The machine complies with the following directives:

- Standard UL 1082
- Canadian Standard CSA C22.2 No. 64

10 Index

A

- Addresses 36
- Aroma preservation cover
 - Bean container with aroma preservation cover 8
- Automatic switch-off 20

B

- Bean container
 - Bean container with aroma preservation cover 8
 - Cleaning 28
 - Filling 10
- Bus bar
 - Technical data 31
- Button
 - On/Off button 9

C

- Cappuccino 16
- Cappuccino doppio 16
- Cappuccino frother cleaning
 - Cleaning the milk system 22
- Cappuccino frother rinsing
 - Rinsing the milk system 22
- Central grounding point 31
- Cleaning
 - Bean container 28
 - Machine 26
- CLEARYL Blue filter cartridge
 - Changing 25
 - Inserting and activating the filter 24
- Coffee 15
 - 2 coffees 15
- Coffee grounds container 8
- Consistency of grind
 - Adjusting the grinder 17
 - Grinder adjustment switch 9
- Contact details 36
- Cup platform 8
- Customer support 36

D

- Descaling
 - Machine 27
 - Water tank 28
- Display
 - Touch display 9, 10

- Display messages 29
- Disposal 31
- Double product 15
- Drip tray 8
- Dual spout
 - Dismantling and cleaning 23
 - Height-adjustable dual spout 8

E

- Emptying the system 31
- Errors
 - Troubleshooting 30
- Espresso
 - 2 espressi 15
- Espresso 15

F

- Filling
 - Bean container 10
 - Water tank 14
- Filter
 - Changing 25
 - Inserting and activating the filter 24
- First-time use 11
 - With filter cartridge activation 11
 - Without filter cartridge activation 12

G

- Grinder adjustment switch 9
- Ground coffee 16
 - Powder chute for ground coffee 9
- Grounding point 31

H

- Hotline 36
- Hot water 18
- Hot-water spout 8

I

- Important safeguards
 - Safety 4
- Instant coffee
 - Ground coffee 16
- Internet 10

J

- JURA
 - Contact details 36
 - Internet 10

L

- Language 21
- Latte macchiato 16
- Latte macchiato doppio 16

M

- Machine
 - Cleaning 26
 - Descaling 27
 - Regular maintenance 19
 - Rinsing 22
 - Setting up 10
 - Switching off 19
 - Switching on 18
- Maintenance 21
 - Daily maintenance 18
 - Regular maintenance 19
- Menu symbol 9
 - Menu symbol 9
- Messages, display 29
- Milk
 - Connecting milk 13
- Milk system
 - Cleaning 22
 - Rinsing 22

P

- Permanently setting the water for the cup size 16
- Permanent settings in programming mode 19
- Powder chute
 - Powder chute for ground coffee 9
- Power cord 8
- Preparation 14
 - 2 coffees 15
 - 2 espressi 15
 - 2 ristretti 15
 - At the touch of a button 15
 - Cappuccino 16
 - Cappuccino doppio 16
 - Coffee 15
 - Espresso 15
 - Ground coffee 16
 - Hot water 18
 - Latte macchiato 16
 - Latte macchiato doppio 16
 - Ristretto 15

- Two specialty coffees 15
 - Using the product selector 15
- Preparation options 15
- Problems
 - Troubleshooting 30
- Product selector view 15
- Programming mode 19
 - Automatic switch-off 20
 - Deactivating the start screen 19
 - Language 21
 - Replacing products on the start screen 19
 - Setting the water hardness 20
 - Unit for amount of water 20

R

- Regular maintenance 19
- Rinsing
 - Machine 22
- Ristretto 15
 - 2 ristretti 15
- Rotary Selection 15

S

- Safety
 - Important safeguards 4
- Settings
 - Permanent settings in programming mode 19
- Setting up
 - Setting up the machine 10
- Short operating instructions 10
- Spout
 - Height-adjustable dual spout 8
 - Hot-water spout 8
- Switching off 19
- Switching on 18
- Switch-off
 - Automatic switch-off 20
- Symbol description 3

T

- Technical data 31
- Tel 36
- Touchscreen display 9, 10
- Transport 31
- Troubleshooting 30
- Two products 15

U

Unit for amount of water 20

Use, First-time 11

W

Water hardness

 Determining the water hardness 12

 Setting the water hardness 20

Water tank 8

 Descaling 28

 Filling 14

Website 10

– intentionally blank –

11 JURA contact details / Legal information

11 JURA contact details / Legal information

Headquarters

JURA Elektroapparate AG
Kaffeeweltstrasse 10
CH-4626 Niederbuchsiten
Switzerland

	USA: JURA Inc.	Canada: FAEMA
Customer Service		
Phone	1-800-220-5701	1-(855)-544-8600
E-Mail	info@us.jura.com	info@juracanada.ca
Opening Hours (EST)	Mon – Thu 9 am – 9 pm Fri 9 am – 8 pm Sat 9 am – 5 pm	
Distributor Address	20 Craig Road Montvale, NJ 07645	115 Matheson Boulevard East Mississauga, Ontario, L4Z 1X8
Phone	001 (201) 767-3999	1-(905)-501-8600
Fax	001 (201) 767-9684	
Internet	www.us.jura.com	www.ca.jura.com

@ You will find additional contact details for your country at **www.jura.com**.

Technical changes

We reserve the right to make technical changes. The diagrams used in these instructions for use are for illustration purposes only and do not represent the original colors of the machine. Some details of your IMPRESSA may vary.

Feedback

Your opinion is important to us! Use the contact link at www.jura.com.

Copyright

The instructions for use contain information which is protected by copyright. It is not permitted to photocopy these instructions for use or translate them into another language without the prior written consent of JURA Elektroapparate AG.