



*Jura*<sup>®</sup>  
CAPRESSO

## Impressa C5

Fully Automatic  
Coffee & Espresso Center  
with Clearyl Blue Water Care System

---

Operating Instructions  
and Warranty

---

Customer Service 1-800-220-5701

# IMPORTANT SAFEGUARDS

When using electrical appliances, basic safety precautions should always be followed, including the following:

1. Read all instructions.
2. Do not touch hot surfaces. Use handles or knobs.
3. To protect against fire, electric shock and personal injury, do not immerse cord, plugs or appliance in water or other liquids.
4. Close supervision is necessary when any appliance is used by or near children.
5. Unplug from outlet when not in use and before cleaning. Allow it to cool before putting on or taking off parts, and before cleaning the appliance.
6. Do not operate any appliance with a damaged cord or plug or after the appliance malfunctions, or has been damaged in any manner. Return appliance to the nearest authorized service facility for examination, repair or adjustment.
7. The use of accessory attachments not recommended by the appliance manufacturer may result in fire, electric shock, or personal injury.
8. Do not use outdoors.
9. Do not let the cord hang over the edge of a table or counter, or touch hot surfaces.
10. Do not place on or near a hot gas or electric burner, or in a heated oven.
11. Always attach plug to appliance first, then plug cord into

wall outlet. To disconnect, turn any control to “off” then remove plug from wall outlet.

12. Do not use appliance for other than intended use.
13. Use extreme caution when disposing hot steam.
14. For household use only.

## SAVE THESE INSTRUCTIONS SPECIAL CORD SET INSTRUCTIONS

Regarding your cord set:

- A. A short power-supply cord (or detachable power-supply cord) is to be provided to reduce risks resulting from becoming entangled in or tripping over a longer cord.
- B. Longer detachable power-supply or extension cords are available and may be used if care is exercised in their use.
- C. If a long detachable power-supply cord or extension cord is used,
  - 1) The marked electrical rating of the detachable power-supply cord or extension cord should be at least as great as the electrical rating of the appliance,
  - 2) If the appliance is of the grounded type, the extension cord should be a rounding type 3-wire cord, and
  - 3) The longer cord should be arranged so that it will not drape over the countertop or tabletop where it can be pulled on by children or tripped over.

**Notice:** Your Impressa C5 has a 3-prong grounded plug. To reduce the risk of electrical shock this plug will fit in an outlet only one way. If the plug does not fit in the outlet contact a qualified electrician. DO NOT modify the plug in any way.

## CAUTION

This appliance is for household use only. Any servicing other than cleaning and user maintenance should be performed by an authorized service representative.

- Do not immerse base in water or try to disassemble.
- To reduce the risk of fire or electric shock, do not remove the base. No user serviceable parts inside. Repair should be done by authorized service personnel only.
- Check voltage to be sure that the voltage indicated on the name plate agrees with your voltage.
- Never use warm or hot water to fill the water container! Use cold water only!
- Keep your hands and the cord away from hot parts of the appliance during operation.
- Never clean with scouring powders or hard implements.

### Customer Service:

**1-800-220-5701**

Mon-Thu 9AM – 9PM • Fri 9AM – 8PM • Sat 9AM – 5PM  
Eastern Standard Time.

email: [contact@jura-capresso.com](mailto:contact@jura-capresso.com)

## JURA-CAPRESSO

Jura was founded in 1931 in Switzerland. Capresso was founded in 1994 in the USA. Both companies have joined forces in the US to bring you the finest Fully Automatic Coffee Centers available anywhere. With innovative and user-friendly features, high quality materials, clear instructions and superb customer service, we are sure you will experience the best coffee, espresso, cappuccino or latte you have ever had. We hope you will enjoy your new Fully Automatic Coffee Center and will recommend it to your friends. For more information about our products visit our website [www.capresso.com](http://www.capresso.com).

## Equipment

Your Impressa C5 comes with:

- One Clearyl Blue filter cartridge
- Dual Frother Plus Steaming / Frothing device
- Two JURA cleaning tablets
- Measuring spoon for pre-ground coffee
- Aquadur® test strip for water hardness testing
- Instruction Manual and Quick Reference Guide
- Mail Order, Registration and Extended Warranty Forms

### Jura-Capresso Inc.

81 Ruckman Road, Closter, NJ 07624

201-767-3999 • Fax: 201-767-9684

Website: [www.capresso.com](http://www.capresso.com)

**Fig. 1**

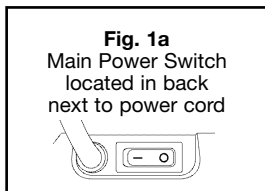
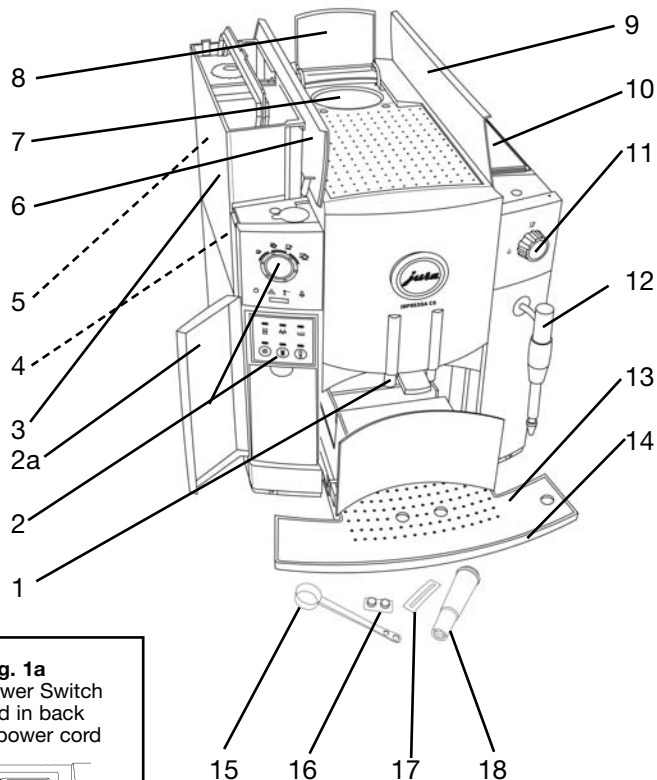

1. Height-Adjustable Coffee Spout
2. DIAL (See Fig. 3) Indicators (See Fig. 3a)
- 2a. Access Door
3. Removable Water Tank
4. Low Water Flotation Device (See Fig. 7.4)
5. Clearyl Blue Water Care Cartridge\*
6. Lid for Water Tank
7. Ground Coffee Funnel
8. Lid for Ground Coffee Funnel
9. Lid for Bean Container
10. Bean Container (See Fig. 5)
11. SELECTOR (See Fig. 4)
12. Dual Frother Plus
13. Stainless Steel Removable Grid
14. Removable Drawer
15. Measuring Scoop
16. Two Cleaning Tablets (white)
17. Water Hardness Indicator Strip
18. Clearyl Blue Water Cartridge (unpacked)

**Fig. 2**

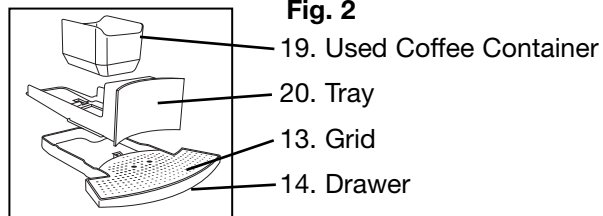

\* Attention: The Water Filter Cartridge should be in a pouch.  
If your machine comes with the cartridge installed, it is not a new machine!  
Call customer service 1-800-220-5701.

**Fig. 3** Operating DIAL with illuminated symbols

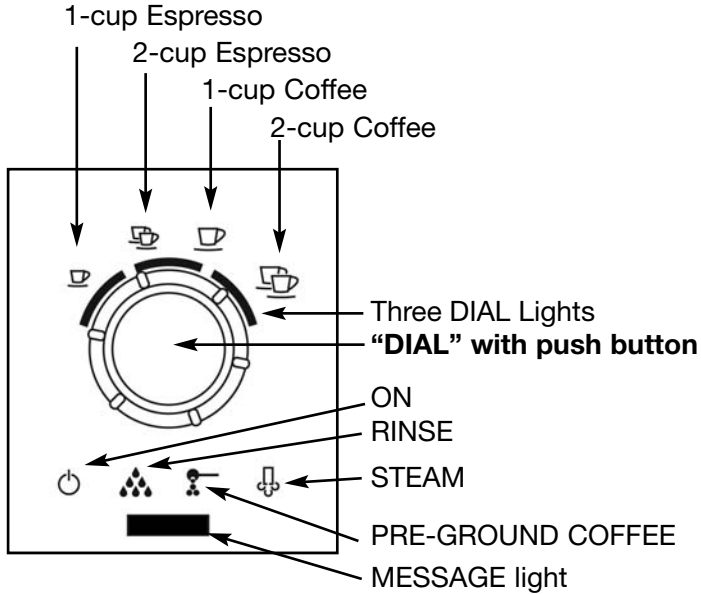

**Fig. 3a** Indicators behind Access Door

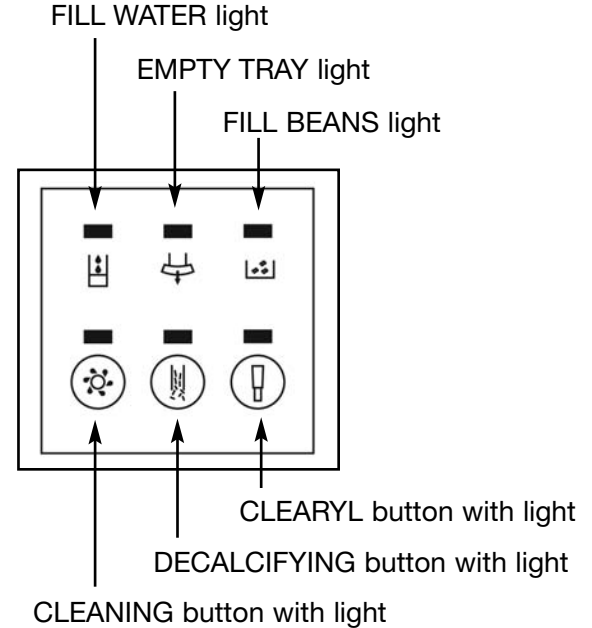

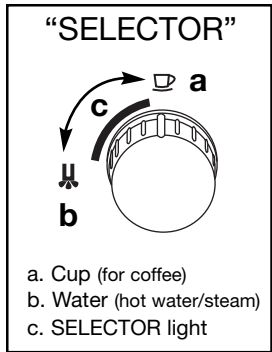

Fig. 4

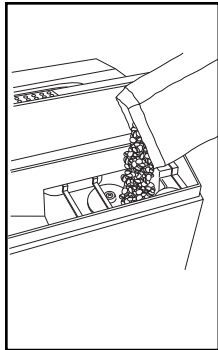

Fig. 5

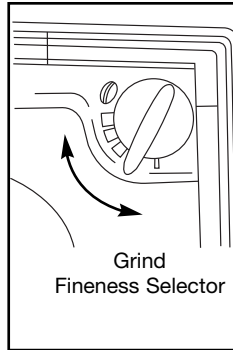

Fig. 6

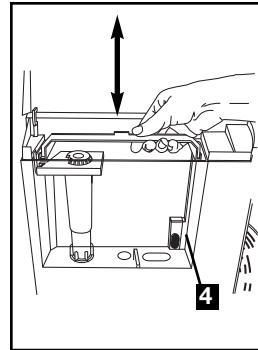

Fig. 7

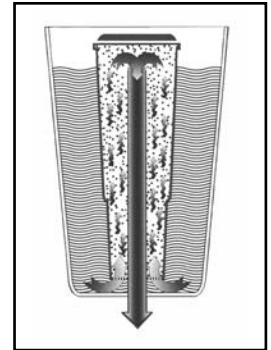

Fig. 8

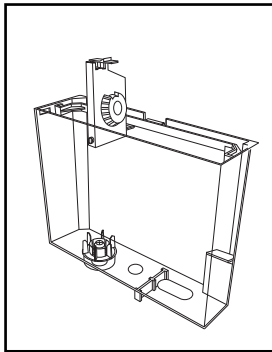

Fig. 9

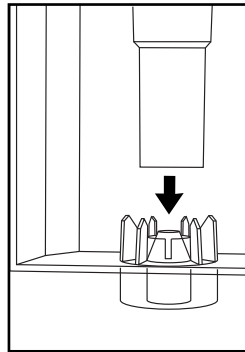

Fig. 10

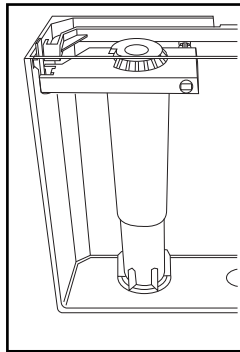

Fig. 11

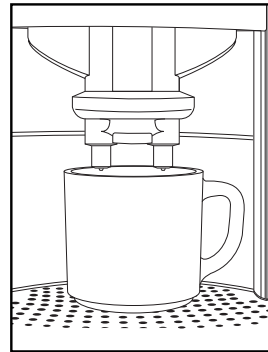

Fig. 12

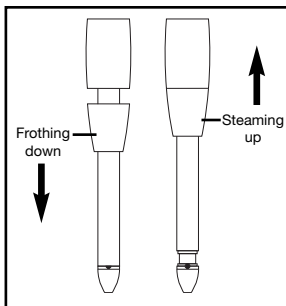

Fig. 13

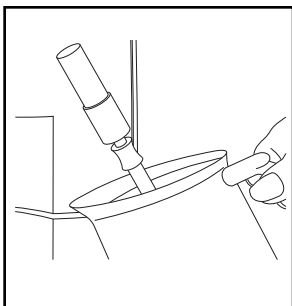

Fig. 14

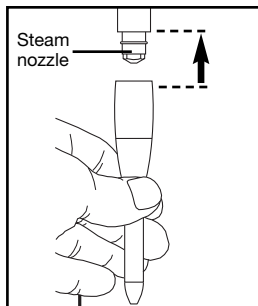

Fig. 15

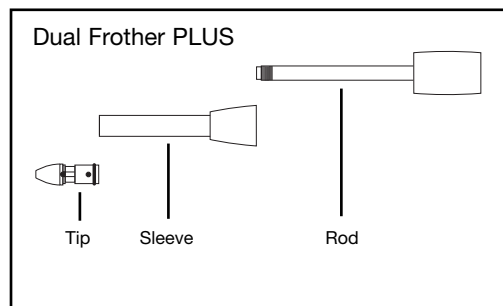

Fig. 16

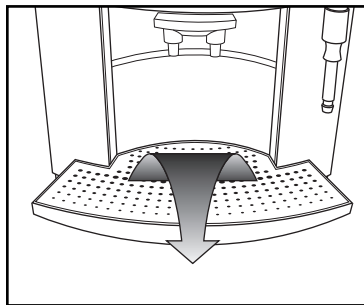

Fig. 17

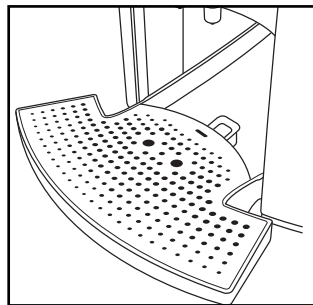

Fig. 18

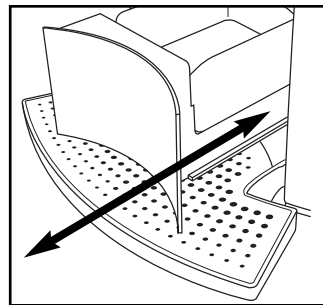

Fig. 19

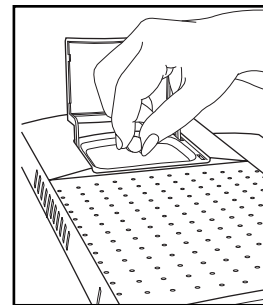

Fig. 20

# Table of Contents

|  | Page |   | Page |
|--|------|---|------|
| Important Safeguards.....                                | 2    | 11. <b>Preparing Cappuccinos and Lattes</b> .....         | 15   |
| Jura-Capresso / Address Information.....                 | 3    | 12. Preparing Hot Milk / Hot Chocolate.....               | 16   |
| Illustrations.....                                       | 4–7  | 13. Cleaning the Dual Frother Plus .....                  | 16   |
| 1. Product Registration.....                             | 9    | 14. Water Care.....                                       | 17   |
| 2. Operating Instructions / Customer Service.....        | 9    | a. Water Hardness Monitor .....                           | 17   |
| 3. <b>Welcome to the Impressa C5</b> .....               | 9    | b. Changing the Water Hardness Monitor .....              | 17   |
| a. "Crema Coffee" and Pressure Brewing .....             | 9    | 15. <b>Clearyl Blue Water Filter Cartridge</b> .....      | 18   |
| b. Different Coffee Drinks.....                          | 10   | a. Installing/Activating the Clearyl Blue Cartridge ..... | 18   |
| c. Coffee Facts.....                                     | 10   | b. Automatic Filter Replacement.....                      | 19   |
| 4. Please Don't / Please Do .....                        | 10   | c. Manual Filter Replacement .....                        | 19   |
| 5. Factory Settings .....                                | 10   | d. Do Not Let the Clearyl Blue Filter Dry Out .....       | 19   |
| 6. <b>Preparing the Machine for the First Time</b> ..... | 11   | 16. <b>Automatic Monitoring</b> .....                     | 19   |
| a. Filling the Water Tank.....                           | 11   | a. Fill Water .....                                       | 20   |
| b. Filling the Bean Container.....                       | 11   | b. Empty Tray / Empty Grounds.....                        | 20   |
| c. Turning the Machine on for the first time.....        | 11   | c. Fill Beans.....  | 20   |
| 7. Adjusting the Grinder .....                           | 12   | d. Stones and Beans.....                                  | 20   |
| 8. <b>Daily Preparation</b> .....                        | 13   | e. General Cleaning Instructions.....                     | 20   |
| a. Turning the Machine Off / Rinsing .....               | 13   | 17. <b>Cleaning with Special Tablet</b> .....             | 21   |
| b. Auto-Off Settings .....                               | 13   | a. Manual Tablet Cleaning.....                            | 21   |
| 9. <b>Coffee Preparation</b> .....                       | 13   | 18. <b>Decalcifying</b> .....                             | 21   |
| a. Pre-warm Cups .....                                   | 13   | a. Manual Decalcifying .....                              | 23   |
| b. Brewing Coffee and Espresso .....                     | 13   | 19. Emptying System Before Transport .....                | 23   |
| c. Brewing Tips .....                                    | 14   | 20. <b>Supplies</b> .....                                 | 23   |
| d. Changing the Cup Size Permanently.....                | 14   | 21. Tips for Better Coffee.....                           | 24   |
| e. Changing the Cup Size Temporarily .....               | 14   | 22. Troubleshooting.....                                  | 24   |
| f. Using Pre-Ground Coffee .....                         | 14   | 23. <b>Warranty</b> .....                                 | 25   |
| 10. Using Hot Water .....                                | 15   | 24. Free Repair Service / Extra Repair Coverage .....     | 26   |



## 1. PRODUCT REGISTRATION

Please read the enclosed product registration form now. Fill it out and mail or fax it to us within two weeks after purchasing your machine or register online through our website: [www.cappresso.com](http://www.cappresso.com). **Important:** This registration is part of your warranty (chapter 23).

## 2. OPERATING INSTRUCTIONS / CUSTOMER SERVICE

Thank you for choosing this Jura product.

- Please study these **Operating Instructions** carefully before using your new machine.
- Also included is a **Quick Reference Guide**. Keep it next to your machine.
- For further information please call our **TOLL FREE number: 1-800-220-5701, Mon-Thur 9AM – 9PM, Fri - 9AM – 8PM, Sat 9AM-5PM Eastern Standard Time**. If you call at any other time leave a message including your phone number and a time you can be reached. You can send us a **FAX at: 201-767-9684** or **EMAIL us at [contact@jura-cappresso.com](mailto:contact@jura-cappresso.com)**.

## 3. WELCOME TO THE IMPRESSA C5

This fully automatic coffee center is extremely user friendly. Your Impressa C5 can prepare one or two cups of crema coffee at a time. The two-step pressure brewing system – well known in commercial applications – was adapted and refined by Jura coffee specialists and is the trademark of each Jura coffee center. This Pre-Brew Aroma-System ensures optimal coffee extraction and will finish every cup with a rich layer of "crema" proof for perfectly pressure brewed coffee. Just select one of four pre-programmed espresso or coffee settings and your

Impressa C5 will grind, tamp and brew your personal cup of coffee. The integrated solid steel conical burr grinder grinds beans to the preferred fineness. A separate funnel lets you use pre-ground coffee. All coffee functions are programmable to your own personal taste. Make any size cup of coffee between 1 and 16 oz. The Dual Frother Plus lets you froth and steam milk for cappuccinos and lattes. The frother delivers unlimited amounts of steam. The stainless steel lined ThermoBlock prevents water from coming in contact with aluminum and allows you to brew coffee immediately after frothing (no purging). The hot water function lets you prepare tea and other beverages in seconds or use it to pre-warm your coffee cups. All important functions such as water level, bean container, used coffee container and water filter are monitored automatically. You can program the machine to turn itself off. The C5 has a beautiful symmetrical design with piano black and chrome accents and a stainless steel grid. Enjoy your Impressa C5!

### 3a. "CREMA COFFEE" AND PRESSURE BREWING

According to the majority of coffee experts, grinding, tamping and brewing under high pressure is the ideal extracting process for maximum flavor and aroma. Your Jura automatic coffee center will always produce espresso and coffee with a thick, foamy layer called "crema." The crema traps the fine aromatics and the light gaseous flavors that register on the palate. The high pressure and the short brewing time prevent the extraction of bitter oils and release less caffeine than any other brewing method. You will always make the absolute freshest and most aromatic cup of coffee. This is the reason why many European restaurants and hotels serve only fresh pressured

brewed coffee. Experiment with your new machine and prepare yourself the best and most enjoyable cup of coffee!

### 3b. DIFFERENT COFFEE DRINKS

Here are some guidelines for the most popular coffee drinks:

- Ristretto: 1/2 to 1 oz. of coffee. Sweeten to taste
- Espresso: 1 to 2 oz. coffee. Sweeten to taste
- Double Shot: 3 to 4 oz. of coffee. Sweeten to taste
- Crema Coffee: 5 to 8 oz. of coffee
- Cappuccino: Espresso plus 3 to 4 oz. of hot frothed milk.
- Latte: Espresso plus 3-5 oz. steamed milk with little or no froth.
- Café Mocha: Make Espresso then add chocolate syrup to the milk before frothing/steaming.

Experiment with the size of your milk based drinks. For stronger coffee taste add more coffee, for more milk taste add more frothed milk.

### 3c. COFFEE FACTS

- **Caffeine** is tasteless. A "strong" coffee or espresso is mostly the result of the amount of coffee in relation to the amount of water. The longer a bean is roasted, the less caffeine it has.
- **Arabica and Robusta** are two genetically different kinds of beans. "Arabica" beans have more flavor and a little less caffeine than "Robusta" beans which are mostly used in lower priced coffees and instant coffees.
- **Espresso** is not a bean, it's the way the coffee is roasted and prepared. Typical US espresso roasts result in darker beans with an oily surface. European espresso roasts are medium brown with no or very little oils on the surface.

**Please note:** Dark, oily beans: see chapter 7.

### 4. PLEASE, DON'T... (or you void your warranty protection):

- Never pull out the drawer during the brewing process.
- Never fill instant coffee into the bean container or ground coffee funnel; it can damage the brewing chamber.
- Never fill flavored or sugar coated coffee beans into the bean container.
- Never fill frozen beans into the bean container. If you store beans in the freezer, let them thaw 3 to 4 hours before filling them into the bean container.
- Never fill anything other than coffee beans into the bean container (no chocolate, rice, nuts, spices, etc.)
- Never fill anything but fresh, cold clean water into the water container, except when decalcifying (chapter 18a).
- Never use mineral or carbonated water. You can use tap water, spring water, distilled water and reverse osmosis water.
- Never repair or open the machine yourself. All repairs should be performed only by an authorized service center.

### PLEASE, DO...

- Fill water tank with fresh, cold water only.
- Remove any foreign particles (small stones) from coffee beans.
- Let frozen beans thaw 3 to 4 hours before pouring them into the bean container.

### 5. FACTORY SETTINGS

The IMPRESSA C5 has four coffee settings. Selecting one of the four coffee symbols (see chapter 9b) will produce approximately the following cup sizes:

1 cup espresso: 1.5 oz.

2 cup espresso: 1.5 oz per cup, total of 3 oz.

1 cup coffee: 5 oz.

2 cup coffee: 5 oz. per cup, total of 10 oz.

All four settings can be re-programmed to your personal preferences (see chapter 9d)

- The grinder can be set during grinding to grind approximately between 5 and 9 seconds, producing a milder or stronger coffee beverage (see chapter 9b)
- The water hardness is set to level 2. If softer or harder water is used, the hardness can be changed (see chapters 14a, 14b).
- The Auto-Off feature is set to 2 hours after last use. See chapter 8b how to change the Auto-Off setting.

## 6. PREPARING THE MACHINE FOR THE FIRST TIME

- Make sure all accessories, literature and any other items are removed from the bean container and the water tank.
- DO NOT install the Clearyl Blue water filter now (chapter 15a).
- Make sure the machine sits on an even, flat surface and the drawer and used coffee container are inserted (Fig. 1 and Fig. 2).
- Plug in machine.

### 6a. FILLING THE WATER TANK

**Please note:** Only use fresh, cold water. Never fill water tank with carbonated water, milk or any other liquid.

- Remove the water tank (Fig. 7), rinse and fill with cold water.
- Replace water tank and make sure that it engages securely. We recommend to fill the water tank each day with fresh, cold water. This will improve the flavor of your coffee.

### 6b. FILLING THE BEAN CONTAINER

**Please note:** To ensure that the conical burr grinder continues to

function properly, please avoid using any kind of coated or flavored beans (all coating and flavors contain sugar or sugar substances). Such coating can damage the burrs. Using such beans voids the warranty. Have your coffee store grind the sugar coated beans and use as described in chapter 9f.

**Flavored Coffee:** If you like flavored coffees we recommend adding flavors to your coffee after brewing. This way you can use your regular coffee beans in the bean container. Adding the flavors after brewing lets you control the flavor intensity much better than with pre-flavored coffee. Your local coffee store typically carries a variety of liquid flavors.

**Frozen Beans:** Thaw 3 to 4 hours before adding to bean container. This prevents moisture from seeping into the grinder.

**Oily Beans:** Beans with an oily surface tend to stick together. This may prevent a continuous flow of beans from the bean container into the burrs. As a result the grinder does not grind enough coffee and you might get weak or no coffee at all. Stir the beans in the bean container just before grinding. Alternatively, you can also pour the beans into an open bowl and let them sit for about 5 hours. The oils will evaporate (this will not change the taste of your coffee). Then fill the beans into the bean grinder. Now beans will feed into the burrs more easily.

- Open the lid for the bean container and remove the Aroma Protection Lid.
- Make sure the bean container is empty and clean. Fill beans into the bean container (Fig. 5).

### 6c. TURNING THE MACHINE ON FOR THE FIRST TIME

Make sure bean container and water tank are filled.

- Switch the Main Power Switch (Fig. 1a) in the back of the

machine. The “ON” symbol (Fig. 3) illuminates, indicating that the main power switch is on.

- Push the DIAL to turn the machine on. The SELECTOR light starts blinking (Fig. 4).
- Place a cup underneath the frother (Fig. 1,12).
- Turn the SELECTOR counterclockwise to the Water symbol (Fig. 4). The machine will dispense a small amount of water through the frother into the cup. During this time the SELECTOR light is on. The water flow stops automatically. The SELECTOR light starts blinking again.
- Turn the SELECTOR clockwise to the Cup symbol. The light turns off.
- The machine heats up indicated by the blinking RINSE symbol (Fig. 3).
- When it stops blinking and is illuminated, place a large cup (8 oz.) under the coffee spouts (Fig. 1,1) and push the DIAL. The machine will rinse and pre-warm the coffee spouts with warm water. During this time the RINSE symbol blinks. After a few seconds the flow of water will stop automatically. All eight symbols around the DIAL are now visible (Fig. 3).
- The 1-cup Espresso symbol is highlighted.
- Push the DIAL. The 1-cup Espresso symbol starts blinking, and the grinder starts grinding beans. The left DIAL light illuminates and the machine brews a first cup of coffee. It will stop automatically.
- Discard the first two cups of coffee.

**Please note:** It is possible during the preparation of just the first cup of coffee that the MESSAGE light (Fig. 3) blinks and no coffee will be produced. The machine has not detected enough ground coffee at this time. (When you open the Access Door

(Fig. 1,2a) the FILL BEANS light blinks (Fig. 3a).

- Just push the DIAL again to brew another cup of coffee.

**Important:** After the brewing stops, the machine will discard the used coffee grounds into the internal used coffee container (Fig. 2). Please do not try to pull out the drawer (Fig. 17-19) during coffee preparation. It can seriously damage the machine. There is no need to pull out the drawer until the machine prompts you (see chapter 6c).

**Important:** Do not remove drawer unless the C5 prompts you (chapter 16b). If you pull out the drawer, you must empty the used coffee container (Fig. 2,19). Otherwise too much used coffee will clog the machine and cause damage.

**Recommendation:** With the 1-cup Espresso symbol highlighted and the other seven symbols dim, turn the DIAL slowly clockwise and see how the other symbols will be highlighted. This is how you select any of the other functions.

## 7. ADJUSTING THE GRINDER

You can adjust the grinder to the roast of your coffee.

We recommend the following:

*Light roast:* use a finer adjustment.

*Dark roast:* use a coarser adjustment.

- Open the lid of the bean container (Fig. 1,9).
- While the grinder is running turn the grind selector to the desired position (Fig. 6).
  - The smaller the dots, the finer the grind.
  - The bigger the dots, the coarser the grind.

**Important:** The grinding grade can only be adjusted while the grinder is actually grinding.

## 8. DAILY PREPARATION

- Fill the water container every morning with fresh, cold water. This will enhance the taste of your coffee.
- Make sure the Main Power Switch is on (Fig. 1a). In this case the ON symbol is illuminated (Fig. 3).
- Push the DIAL. The RINSE symbol (Fig. 3) blinks, indicating that the machine is heating up.
- When the RINSE symbol stops blinking, place a cup under the coffee spouts and push the DIAL. The machine will rinse some water through the coffee spouts and will stop automatically. All eight symbols around the DIAL are now visible.

The 1-cup Espresso symbol is highlighted.

The machine is ready to make coffee.

### 8a. TURNING THE MACHINE OFF / RINSING

The machine will automatically turn off 2 hours after last use. At this time it will rinse some hot water through the coffee spouts. We recommend that you keep a cup under the coffee spouts.

### 8b. AUTO-OFF SETTINGS

The C5 is pre-set to turn itself off 2 hours after last use. You can select and program the auto-off interval to 1, 2, 4 or 8 hours after last use. You can set the machine not to turn itself off.

#### **Auto off after: Cup symbols highlighted in programming**

|            |                      |
|------------|----------------------|
| Not active | no cup symbols on    |
| 1 hour     | one cup symbol on    |
| 2 hours    | two cup symbols on   |
| 4 hours    | three cup symbols on |
| 8 hours    | four cup symbols on  |

**Example:** Change the auto-off from 2 to 4 hours after last use.

The C5 is turned off, but in stand-by mode. Only the ON symbol is visible.

- Open the Access Door (Fig. 1,2a).
  - Push and hold the CLEANING button (Fig. 3a) until its red light is on. The display shows 2 symbols highlighted above the DIAL (for 2 hour auto-shut off).
  - Turn the DIAL until four symbols are highlighted.
  - Push the DIAL to confirm the new setting.
- The machine automatically returns to the stand-by mode. From now on the auto-shut off is set to 4 hours after last use.

## 9. COFFEE PREPARATION

### 9a. PRE-WARM CUPS

The machine is ready to make coffee (All eight symbols around the DIAL are visible. The 1-cup Espresso symbol is highlighted. Before brewing coffee we recommend pre-warming your cup(s) with the hot water feature. Cold cups reduce the coffee temperature by 5°F to 10°F.

- Place a cup under the frother (Fig. 1,12).
- Turn the SELECTOR counterclockwise to the Water symbol (Fig. 4). The machine will dispense hot water through the frother into the cup.
- Turn the SELECTOR back to the Cup symbol to stop the hot water flow. Discard the water. Now your cup is pre-warmed.

### 9b. BREWING COFFEE AND ESPRESSO

The machine has four pre-set coffee and espresso symbols (Fig. 3).

**In the 2-cup selection** - the grinder grinds the maximum amount of coffee (grinding time approx. 9 seconds).

**In the 1-cup selection** - the grinder grinds the minimum amount of coffee (grinding time approx. 5 seconds).

**Brewing one cup:**

- Place a cup under the coffee spouts.
- Adjust the height of the coffee spouts to fit the cup (Fig. 12).
- Turn the DIAL to highlight either the 1-cup Espresso or the 1-cup Coffee symbol.
- Push the DIAL. The machine will grind, tamp and then brew the coffee. During the preparation the selected cup symbol will blink. The machine uses a 2-step brewing process (pre-brew phase), pauses for a few seconds, and then starts the brewing process. When brewing is finished, the display will highlight the last cup selection.

**Brewing two cups:**

- Place two cups under the Dual Coffee Spouts and turn the DIAL to highlight the 2-cup Espresso or Coffee symbol.
- Push the DIAL. The machine will grind the maximum amount of coffee and will produce twice as much volume as in the 1-cup selection (see chapter 5 Factory Settings).

**9c. BREWING TIPS**

**Stop Brewing:** You can always stop the brewing process by pushing the DIAL during brewing. This will not change the programmed cup size.

**Stronger Coffee:** To increase the strength of the coffee in the 1-cup selection turn the DIAL during grinding to the right (clockwise) until two or three light segments illuminate. This will prolong the grinding time, making the coffee stronger.

**Weaker Coffee:** If the coffee is too strong, add a bit of hot water

with the Hot Water Feature. Place the cup with the coffee under the frother and turn the SELECTOR to the Water symbol. Hot water will be added to your coffee. Turn the SELECTOR back to the Cup symbol to stop the hot water flow.

**9d. CHANGING THE CUP SIZE PERMANENTLY**

All four Cup symbols can be customized to your personal cup size. The machine is ready to brew coffee.

- Place a cup under the coffee spouts. Highlight the coffee symbol you want to re-program, e.g. the 1-cup Coffee symbol.
- Push and hold the DIAL until the left DIAL light starts blinking. During brewing the left segment keeps blinking, indicating that the machine is in programming mode.
- Once the cup is filled with the desired amount of coffee push the DIAL again. From now on the machine will produce this cup size for this symbol.

You can re-program all four coffee symbols in the same way. The C5 will keep the information, even if it is unplugged.

You can change the cup size anytime, using the same procedure.

**9e. CHANGING THE CUP SIZE TEMPORARILY**

The machine is ready to brew coffee.

Highlight the cup symbol you want to use and push the DIAL. When the brewing starts, you can increase the volume of the coffee by turning the DIAL clockwise. In this case the programmed cup size is not changed.

**9f. USING PRE-GROUND COFFEE**

You can also use pre-ground coffee, bypassing the grinder. This is convenient if someone requests decaf coffee, decaf cappuccino

or flavored coffee.

The machine is ready to make coffee. The cup is placed under the coffee spouts.

- Turn the DIAL to highlight the PRE-GROUND COFFEE symbol (Fig. 3).
- Push the DIAL. The PRE-GROUND COFFEE symbol blinks.
- Open the lid for pre-ground coffee (Fig. 1,8) and fill 1 or 2 level measuring scoops of ground coffee into the funnel (Fig. 1,7).
- Turn the DIAL to highlight one of the four coffee symbols and push the DIAL.

The machine will now tamp (not grind) the coffee and brew it.

**Please note:** Never fill the funnel with instant coffee. Do not fill the funnel with more than two scoops. The funnel is not a storage container. If coffee is ground too fine the brewing process may be stopped.

**Please note:** If the PRE-GROUND COFFEE symbol blinks and you do not want to use pre-ground coffee, push the DIAL again. The machine realizes that there is no coffee to tamp and will stop the brewing process by itself. The display will automatically return to the normal ready position.

## 10. USING HOT WATER

The hot water function lets you pre-warm cups, brew tea, make a quick cup of soup, or add hot water to your coffee or espresso to create a milder flavor.

We recommend removing the Dual Frother Plus. Just pull it down (Fig. 15). This will ensure that the hot water will come straight out of the steam nozzle. With the Dual Frother Plus removed taller cups and glasses will fit underneath the steam nozzle.

The machine is ready to make coffee.

- Place a cup under the steam nozzle.
- Turn the SELECTOR counterclockwise to the Water symbol (Fig. 4). The machine will dispense hot water.
- Turn the SELECTOR back to the Cup symbol to stop the hot water flow.

## 11. PREPARING CAPPUCCINOS AND LATTES

**Frothing milk for Cappuccino:** Injecting hot steam into the milk to warm the milk and create a frothy layer of tiny bubbles.

**Steaming milk for Latte:** Injecting hot steam to warm the milk without creating a frothy layer.

The Dual Frother Plus is already attached. Make sure it is pushed up completely against the steam nozzle (Fig. 15).

**Caution:** If the Dual Frother is not attached properly or it is clogged (see chapter 13) it is possible that it can be pushed off during steaming. This can cause burns and injuries.

**Frothing Position:** The sleeve of the frother is pushed down.

**Steaming Position:** The sleeve is pushed up (see Fig. 13 & 16).

The machine is ready to make coffee.

1. Fill the desired amount of milk into a pitcher or in your cup. Make sure that the pitcher or the cup has at least twice the volume of the milk, e.g. if you steam or froth 5 oz. of milk use a 10 to 12 oz. pitcher.
2. Turn the DIAL to highlight the STEAM symbol (Fig. 3) and push the DIAL. The STEAM symbol blinks indicating an increase in temperature for steaming.
3. When the temperature is reached the SELECTOR light blinks (Fig. 4,c), indicating that the machine is ready to release steam.

4. Now immerse the frother into the milk (Fig. 14) and turn the SELECTOR to the Water symbol. Immediately hot steam will be released into the milk.

**With the sleeve pushed down** - (Fig. 13) small frothing bubbles will build up on the surface.

**With the sleeve pushed up** - steam will heat up the milk without creating froth.

- When you are finished with frothing/steaming turn the SELECTOR back to Cup symbol. Steam output will stop immediately. The SELECTOR light starts blinking again.
- Now remove the pitcher or the cup from the frother.

**Please note:** As long as the SELECTOR light blinks you can steam more milk. Once the SELECTOR light turns off you need to heat up the thermoblock to create steam (see steps 1-4 above).

- Use a cappuccino cup and prepare an espresso or double espresso (see chapter 9b). Add the hot milk and froth to taste.

#### **Tips for frothing (Cappuccino):**

- The frother tip should not touch the bottom of your pitcher. Start in the steaming position – sleeve "up" (Fig. 13) – for a few seconds. Then push the sleeve "down". Milk froth will build up. This way the froth on top of your milk is also warm.
- Steaming and frothing directly in your cappuccino/latte cup: With practice, you can steam and froth directly in your cappuccino cup. First steam and froth the milk, then add your espresso shot.
- For two cappuccinos or lattes prepare enough froth/steamed milk, then brew your espressos and add the milk for both.
- **Hotter Milk:** If the frothed milk is not hot enough, continue to inject hot steam in the steaming position.

**Please note:** When you stop steaming the display automatically highlights the 1-cup Espresso symbol. You can add coffee immediately after frothing milk. No purging necessary.

## **12. PREPARING HOT MILK / HOT CHOCOLATE**

The steam feature can be used to prepare a cup of hot steamed milk or hot chocolate. To steam milk and to steam and froth chocolate milk follow the instruction in chapter 11.

**Tip:** If you use chocolate powder for your hot chocolate, first add it to the cold milk and dissolve the chocolate powder, then steam and froth.

## **13. CLEANING THE DUAL FROTHER PLUS**

Always keep the Dual Frother Plus clean. The two side holes and the groove of the frother tip must be free of milk deposits (Fig. 16). If these parts contain hardened milk particles, it will be impossible to froth milk properly.

#### **Fast cleaning:**

- Place a cup underneath the frother and turn the SELECTOR to the Hot Water/Steam position (Fig. 4). Let hot water run through the frother for about 3 seconds and then stop. This will flush out any small milk droplets.

#### **Thorough cleaning:**

Remove the Dual Frother from the Steam Nozzle (Fig. 15) and unscrew the tip from the rod (Fig. 16). Make sure the two side holes, the bottom opening and the groove in the tip are completely free of any hardened milk deposits (use hot soapy water and a cleaning brush). Rinse all parts thoroughly with fresh water and replace. Make sure the tip is screwed on to the rod properly



(hand tight) and the frother is completely pushed up against the steam nozzle (Fig. 15).

**CAUTION:** If the tip of the frother is blocked by hardened milk deposits it is possible that the frother can be pushed off during steaming. This can cause burns and injuries.

#### 14. WATER CARE

The C5 works with tap water, bottled water, distilled water. We recommend using tap water or bottled water. Distilled water has no minerals and does not improve the taste of coffee. Water that is heated inside the machine leads to calcium deposits.

Tap water has a varying degree of water hardness (chapter 14a). Most bottled water has a low level of water hardness.

**IMPORTANT:** do not use carbonated water or any other liquid in the water tank.

You have the following options to take care of the water.

- Decalcifying System (chapter 18). The machine is factory pre-set to automatically remind you to decalcify.
- Clearyl Blue Water Filter Cartridge (chapter 15a).

##### 14a. WATER HARDNESS MONITOR

The C5 is set to a medium hard water level (level 2 below). The C5 can be set to five different water hardness settings (see below). If you are not sure about the hardness of your water ask your local water company for the "Water Hardness in Grains." You can also use the water hardness indicator strip ("Aquadur" Fig. 1,16) to determine the water hardness:

- Insert the strip for one second into the water you want to use.
- Shake off any access water and wait for one minute.

One or more sections of the indicator strip will turn reddish. The more sections turn reddish the harder your water is. If all four sections turn reddish your tap water is very hard (level 4 below). You might want to consider using bottled water.

- Change the water hardness setting according to the table below.

| Level | Water hardness Level in grains | Cup symbols highlighted in programming... |
|-------|--------------------------------|---|
| 0     | Hardness monitor is off        | no cup symbol on                          |
| 1     | 2 to 9 grains                  | one cup symbol on                         |
| 2     | 10 to 19 grains                | two cup symbols on                        |
| 3     | 20 to 29 grains                | three cup symbols on                      |
| 4     | 30 + grains                    | four cup symbols on                       |

**Please note:** If you use Spring or Bottled Water with low calcium levels you can set the hardness to level 1 above.

##### 14b. CHANGING THE WATER HARDNESS MONITOR

**Example:** Change the hardness setting from level 2 to level 1. Your machine is turned off, but in stand-by mode. Only the On symbol is visible.

- Open the Access Door (Fig 1,2a).
- Push and hold the DECALCIFYING button until its light is on. Two of the cup symbols above the DIAL will be highlighted.
- Turn the DIAL until only one symbol is highlighted.
- Push the DIAL to confirm the new setting. The machine will return to stand-by mode.

**Please note:** You can turn off the hardness monitor (level 0). In this case you must use distilled water. The machine will not remind you to decalcify the inner parts.

## 15. CLEARYL BLUE WATER FILTER CARTRIDGE

The machine comes with one Clearyl Blue Water Filter Cartridge. The Clearyl Blue cartridge

- Reduces the water hardness up to 75%.
- Removes (if present) up to 85% chlorine, up to 90% lead, up to 95% copper and up to 67% aluminum.
- Cleans the water through an upward current principle (Fig. 8) just before the brewing cycle starts, ensuring freshly filtered water every time you make coffee.
- Lasts for 60 liters (~2,000 oz.) of water or up to two months.
- Eliminates decalcifying except when using very hard water (30 grains or higher), see chapter 14a. In this case we recommend to decalcify the machine once or twice a year.
- To reorder cartridges, see chapter 20.

### 15a. INSTALLING & ACTIVATING THE FILTER CARTRIDGE

**Important:** In order for the Clearyl system to work properly you must install and activate the system (see below).

#### Installing:

**Important:** Never install the cartridge before or during "Preparing Machine For The First Time" (chapter 6).

- Remove cartridge from its bag and rinse cartridge under water.
- Remove the water tank, make sure it is empty.
- Pull up the cartridge holder (Fig. 9) and insert the cartridge with its tapered end down into the water container (Fig. 10). Make sure it fits inside the fins and push down gently.
- Close the cartridge holder making sure it snaps into place (Fig. 11).
- Fill the water tank with fresh cold water and replace.

#### Activating:

You must activate the cartridge for the machine to monitor it properly. Otherwise the C5 assumes decalcifying mode. Your machine is turned off, but in stand-by mode. Only the ON symbol is visible.

- Open the Access Door (Fig 1,2a).
- Push and hold the CLEARYL button until its light is on (Fig. 3a).
- Turn the DIAL until all three DIAL lights are illuminated.
- With the three lights illuminated push the DIAL to confirm the activation process. The three lights begin to blink.
- Place a 20 oz. container under the steam nozzle (Fig. 15).
- Turn the SELECTOR to the Water symbol.

The C5 pumps water through the cartridge and out through the steam nozzle for approximately 60 seconds. Initially, the water may be discolored. The program will stop automatically.

- Turn the SELECTOR back to the Cup symbol.

The machine will return to stand-by mode. From now on, the machine will monitor the flow of water. After using approx. 60 liters(~2,000 oz.) of water, the machine will remind you to replace the filter (see below).

**Please note:** You can stop the water flow at any time by turning the SELECTOR to the Cup symbol. Empty the container, replace and turn the SELECTOR to the Water symbol to complete the activation process.

**Please note:** As long as the filter is activated, the water hardness setting is automatically turned off.

### 15b. AUTOMATIC FILTER REPLACEMENT

The filter is monitored automatically. After approx. 60 liters of water (~2,000 oz.) the MESSAGE light and the CLEARYL light (Fig. 3a) illuminate, indicating that it is time to change the filter.

**Important:** Once the filter has lost its calcium suppressing abilities, calcium will build up inside the machine. Since the Water Hardness Selector is off, the machine will not remind you when to decalcify. If the filter is not replaced, the calcium build-up will clog and damage your machine.

1. Remove the water tank and the old filter. Make sure the water tank is empty.
2. Remove a new cartridge from its bag, rinse under running water and insert in water tank.
3. Close the cartridge holder. Make sure it snaps into place.
4. Fill the water tank with water and replace.
5. Push and hold the CLEARYL button until its light blinks.
6. Place a 20 oz. container under the steam nozzle.
7. Turn the SELECTOR to the Water symbol.

The C5 pumps water through the cartridge and out through the steam nozzle for approximately 60 seconds. Initially, the water may be discolored. The program will stop automatically.

8. Turn the SELECTOR back to the Cup symbol.

The RINSE symbol blinks, indicating the machine is heating up.

### 15c. MANUAL FILTER REPLACEMENT

If the filter is more than 2 months old and the display does not indicate to replace filter, replace as follows.

Your machine is turned off, but in stand-by mode. Only the ON symbol is visible. Now follow the instructions in chapter 15b, steps 1–8.

### 15d. DO NOT LET THE CLEARYL BLUE FILTER DRY OUT

If the filter is not immersed in water, the granular center will dry out and block any water from passing through.

- If machine is not used for a few days, leave some water in the water tank so the filter will not dry out. Upon using the machine again, fill the water tank with fresh water and process approx. 2 oz. of water through the hot water spout.
- If the machine will not be used for a longer period of time, empty the water container and remove the Clearyl Blue filter. Fill a glass with at least 2 inches of water and immerse the filter.
  - Place the glass in the refrigerator.
  - When you use the machine again, install the filter. Activation is not necessary.

### 16. AUTOMATIC MONITORING

The machine has built-in systems to automatically monitor all vital functions, such as

- filling the water tank (chapter 16a),
  - emptying the used coffee container (chapter 16b),
  - filling beans (chapter 16c),
  - replacing the Clearyl Blue water cartridge (chapter 15b),
  - cleaning program with special tablet to remove internal coffee oil build-up (chapter 17).
- Whenever the MESSAGE LIGHT lights up or blinks, open the ACCESS door. One of the red lights will also be on or blinking, indicating the cause for the message.

### 16a. FILL WATER

When the MESSAGE LIGHT and the FILL WATER light blink, no more coffee can be made until you fill the water container. The water container will never be completely empty. The low water floatation device (Fig. 7.4) activates the above message when there is about 10 oz. of water left.

- Remove water tank, rinse and fill with fresh water and replace. The above message will turn off and you can make coffee again.

### 16b. EMPTY TRAY / EMPTY GROUNDS

When the MESSAGE light and the EMPTY TRAY light blink, no more coffee can be made until the tray is removed and emptied.

- Carefully lift and remove drawer since there is water in it (Fig. 17).

**Important:** Do not unplug the machine while you are emptying the coffee grounds.

- Empty the used coffee container and the drawer.
- Push the drawer back into the machine (Fig. 18).
- Place the used coffee container on the tray and insert back into the machine (Fig. 19).

The above message will turn off and you can make coffee again.

### 16c. FILL BEANS

When the MESSAGE light and the FILL BEANS light blink, open the bean container lid and add beans (Fig. 5).

**Please note:** This message will disappear after making the next cup of coffee.

**Attention:** If the message appears and there are ample beans in the bean container, stir the beans so they flow into the grinder (chapter 6b). We recommend cleaning the bean container from time to time with a dry cloth before you refill beans (please make sure the machine is turned off when cleaning).

### 16d. STONES AND BEANS

Every coffee specialty store will tell you that occasionally small stones can be found in with coffee beans. Small stones will be processed through the burr grinder without any harm (the stone will end up in the used coffee container).

However larger stones can block the burr grinder. The noise of the grinder will become very loud and the grinder will block. In this case please call our Customer Service: 1-800-220-5701.

Before Filling Beans into the Bean Container:

- Shake your bean bag thoroughly so that a stone will fall to the bottom of the bag.
- Before emptying the bean bag completely, check if there are any particles that look like stones and remove them.

### 16e. GENERAL CLEANING INSTRUCTIONS

Never use abrasive materials or chemicals to clean the machine.

- Clean the housing with a soft, damp cloth.
- Rinse water tank daily and fill with fresh, cold water.

### 17. CLEANING WITH SPECIAL TABLET

The machine monitors how many coffees are brewed and how often the rinsing program is activated. After approx. 200 coffees the MESSAGE light and the CLEANING light (Fig. 3a) will illuminate. It is time to perform a tablet cleaning cycle.

This cleaning program will remove oil build-ups in the brewing chamber. The cleaning program takes about 15 minutes.

**Please note:** You can continue making coffee, however we highly recommend that you clean the machine as described below within the next few days. Please use one of the two white cleaning tablets (Fig. 1,16). To order more tablets see chapter 20.

**Important:** Once the cleaning program has started do not interrupt the procedure.

The MESSAGE light and the red CLEANING light are illuminated.

**Important:** Keep the Access door open during the cleaning process to observe the various light indicators.

1. Push and hold the CLEANING button until its light blinks.  
Make sure the water tank is at least half full.
2. Now the EMPTY TRAY light blinks, too.
3. Remove and empty the drawer and used coffee container and replace complete assembly (Fig. 19).
4. **Important:** Even if the drawer and the used coffee container are empty, you still need to remove them for approx. 20 seconds and then replace them.
5. The CLEANING light is on (stops blinking).
6. Place a large cup (at least 12 oz.) under the coffee spouts.
7. Push the CLEANING button (Fig. 3a). The C5 disperses water through the coffee spouts. Then the PRE-GROUND COFFEE symbol blinks (Fig. 3).
8. Open the ground coffee lid and drop in one white cleaning tablet (Fig. 20) and close lid.
9. Push the CLEANING button. The cleaning program will dispense foamy water in intervals through the coffee spouts. This will take a few minutes. The CLEANING light blinks.
10. After a few minutes the EMPTY TRAY light blinks.
11. Lift and remove the drawer. Empty the used coffee container and drawer and replace.
12. The RINSE symbol blinks indicating that the machine is heating up.

The C5 automatically remind you when it's time to run this cleaning cycle again. The machine is now ready to brew coffee again.

## 17a. MANUAL TABLET CLEANING

**Attention:** You can run a tablet cleaning cycle at anytime even if the machine does not prompt you.

The machine is ready to brew coffee.

- Push and hold the CLEANING button until the MESSAGE light, the CLEANING light and the EMPTY TRAY light blink.
- Continue with step 3 above.

## 18. DECALCIFYING

The machine has an integrated decalcifying program. This program takes 45 minutes. When the MESSAGE light and DECALCIFYING light are both on, it is time to decalcify the machine.

You can still make coffee. It is recommended to decalcify the machine within the next 4 to 5 days.

You can buy decalcifying tablets from your local Jura dealer or with the enclosed mail order form (see chapter 20). One package contains three sets of three tablets, good for three decalcifying procedures.

**Please note:** If you use the Clearyl Blue water cartridge and the decalcifying message shows up, your cartridge function was not activated. Follow the instructions in chapter 15a to activate the Clearyl Blue cartridge. If the cartridge is in use for several weeks install a new cartridge.

**Important:** The decalcifying program must not be interrupted.

**NOTE:** Only use our special, square decalcifying tablets, see chapter 20.

**CAUTION:** Never use vinegar or any other decalcifying agent. This might damage internal parts of the machine.

**CAUTION:** Immediately remove any splashes of the decalcifying solution from sensitive surfaces, such as natural stone or wood.

**CAUTION:** If the decalcifying solution comes in contact with the skin, rinse it off with water. If the solution comes in contact with your eyes, see a doctor.

**Important:** Always wait until the decalcifying solution in the water tank has been used up. Do not fill additional decalcifying solution or water into the water tank.

The MESSAGE light and the DECALCIFYING light are both on.

**Important:** Keep the Access door open during the decalcifying process to observe the various light indicators.

- Push and hold the DECALCIFYING button until its light blinks. Now the EMPTY TRAY light blinks, too.
- Remove and empty the drawer and used coffee container and replace complete assembly (Fig. 19).

**Important:** Even if the drawer and the used coffee container are empty, you still need to remove them for approx. 20 seconds and then replace them.

1. The FILL WATER TANK light blinks (Fig. 3a).
2. Remove the water tank and make sure it is empty.
3. Dissolve 3 white square tablets in 16 oz. of water, pour the mixture into the water tank and replace water tank.
4. The SELECTOR light blinks (Fig. 4,c).
5. Remove the Dual Frother (see Fig. 15).
6. Place a container (at least 16 oz.) under the steam nozzle.
7. Turn the SELECTOR to the Water symbol. The machine will pump the mixture through the steam nozzle in intervals. During this procedure the SELECTOR light is on. When this cycle is finished, the machine stops pumping and the SELECTOR light blinks.
8. Turn the SELECTOR back to the Cup symbol. Now the C5 continues to pump the descaling mixture through

the internal brew chamber into the used coffee container. The machine stops pumping the solution and the EMPTY TRAY light blinks.

9. Remove the container from under the Steam nozzle.
10. Carefully lift and remove the drawer, empty and thoroughly rinse all parts and replace.
11. Now the FILL WATER light blinks.
12. Remove the water tank, rinse thoroughly, fill with cold fresh water and replace.
13. Place a container (at least 16 oz.) under the steam nozzle.
14. The SELECTOR light blinks (Fig. 4,c).
15. Turn the SELECTOR to the Water symbol. The machine will pump fresh water through the steam nozzle in intervals. During this procedure the SELECTOR light is on. When this cycle is finished, the C5 stops pumping and the SELECTOR light blinks.
16. Turn the SELECTOR back to the Cup symbol. Now the C5 continues to pump fresh water through the internal brew chamber into the used coffee container. The C5 stops pumping and the EMPTY TRAY light blinks.
17. Remove the container from under the Steam nozzle.
18. Carefully lift and remove the drawer, empty and thoroughly rinse all parts and replace.
19. The decalcifying procedure is complete. The RINSE symbol blinks indicating that the machine is heating up.
20. The machine will automatically remind you when it's time to decalcify again.
21. Replace the Dual Frother.  
The machine is ready to brew coffee again.

## 18a. MANUAL DECALCIFYING

**Attention:** You can run a decalcifying program at anytime even if the machine does not prompt you.

The machine is ready to brew coffee.

- Push and hold the DECALCIFYING button until the MESSAGE light, DECALCIFYING light and the EMPTY TRAY light blink.
- Remove and empty the drawer and used coffee container and replace complete assembly (Fig. 19).
- Continue with steps 1– 21 of chapter 18) above.

## 19. EMPTYING SYSTEM BEFORE TRANSPORT

This procedure is necessary to prevent water and frost damage in case you intend to transport your machine.

The machine is ready to make coffee.

- Place a cup underneath the frother.
- Turn the DIAL to highlight the STEAM symbol (Fig. 3).
- Push the DIAL. The machine will heat up to steam. When the SELECTOR light is illuminated, turn the SELECTOR to the Water symbol. Steam will be released into the cup.
- During the steam release, remove the water container. As soon as there is no steam any longer in the system, the SELECTOR light will blink and the steam will fade.
- Turn the SELECTOR back to the cup symbol. Disregard any blinking lights at this time.
- Push the DIAL. No more lights are blinking. The machine is now in stand-by mode.
- Turn the Main Power Switch (Fig. 1a) in the back of the machine off.

**Important:** The next time you turn the machine on you must

follow the instructions in chapter 6.

**Please note:** Before transporting the machine, make sure that the water tank is empty, the filter cartridge is removed (discard and use a new filter), the bean container is empty, the drawer and used coffee container are empty and clean. Secure the lids of the water tank and the bean container with scotch tape. Pack entire machine with thick cushioning material on all sides to prevent damage.

## 20. SUPPLIES

The following supplies are necessary to keep your machine in good working order:

- Clearyl Blue Water Filter Cartridge (one included). Model #67879; the machine will remind you automatically.  
**Tip:** If you brew 10 cups a day you need about one Clearyl Blue cartridge per month. Always keep extra cartridges available.
- Special Cleaning Tablets (two included).  
**Tip:** If you brew 10 cups a day you need about one tablet every three weeks.
- Decalcifying tablets (large square tablets) - Model #61848.  
**Please note:** You must use decalcifying tablets if you do not use the Clearyl Blue filter.  
You can order these supplies:
  - with the enclosed mail order form or
  - through our website [www.cappuccino.com](http://www.cappuccino.com) or
  - by calling our customer service center at 1-800-220-5701.

## 21. TIPS FOR BETTER COFFEE

### **Height adjustable coffee-spout**

Adjust the height of the coffee-spout to the size of your cups.

### **Grinding**

Please refer to chapters 6 and 7.

### **Hotter Coffee / Pre-warm cups**

You should warm cups in advance with hot water or steam.

The smaller the quantity of coffee, the more important it is to warm your cups (see chapter 9a).

### **Hotter Cream and Milk**

Adding milk or cream from the refrigerator considerably lowers the temperature of the coffee. Preheat milk and cream with the steam function then brew your coffee (see chapter 11).

## 22. TROUBLESHOOTING

### **A. NO COFFEE COMES OUT OF THE COFFEE SPOUT**

**Concern:** Beans in bean container are not properly feeding into the grinder because they are stuck together.

**Solution:** Stir beans before grinding and while grinding turn the grinding selector to the coarsest setting. See chapter 7.

**Concern:** You used ground coffee in the ground coffee funnel. The ground coffee was too fine.

**Solution:** Use ground coffee which is ground somewhat coarser.

**Concern:** No water is transported through the system.

**Solution:** Remove water container and make sure that the connecting valve is free of any particles (like a coffee bean etc).

**Concern:** The ground coffee funnel or the internal brewing chamber is clogged.

**Solution:** Place a cup underneath the coffee spout. Turn the DIAL to highlight the RINSE symbol. Push the DIAL to rinse the coffee spouts. Repeat the process if necessary until the blocked coffee is pushed into the used coffee container.

### **B. INSUFFICIENT FROTHED MILK PRODUCTION**

**Concern:** Milk is initially not cold enough or your milk is not suited for thick frothing.

**Solution:** Make sure milk is cold. Use a different type of milk. Skim milk will produce the thickest and longest lasting froth. Whole milk will produce less thick froth.

**Concern:** The components of the frother are not assembled properly, or the components are clogged with hardened milk, or one or more of the components is missing, or the steam nozzle is clogged.

**Solution:** (See chapter 13)

- Remove frother. Check that steam comes out of the steam nozzle. If not, use a needle and clear blockage from inside steam nozzle.
- Clean all other frother parts and assemble properly.
- If any parts are missing either call Customer Service at: 1-800-220-5701 or use the enclosed mail order form to order the missing part.

### **C. GRINDER MAKES AN EXTREMELY LOUD NOISE; NO BEANS ARE GROUND**

**Concern:** A stone is blocking the burr grinder.

**Solution:** Call customer service at: 1-800-220-5701.



#### **D. THE DRAWER (Fig. 19) DOESN'T PULL**

**Solution:** Turn off and unplug machine. Wait a minute. Turn machine on and wait until it stops making any noise. Now try to pull out the drawer. If this does not work, try the above procedure again. If this does not work, call customer service.

#### **E. THE MESSAGE LIGHT AND ALL INDICATOR LIGHTS BEHIND THE ACCESS DOOR BLINK**

**Solution:** Call customer service at: 1-800-220-5701.

#### **23. LIMITED TWO-YEAR WARRANTY**

**Please note:** This warranty will be void if the Warranty / Product Registration has not been received two weeks after the purchase date (you can fax or mail the registration or you can register through our website [www.cappresso.com](http://www.cappresso.com))

This limited warranty covers your new Jura-Cappresso C5 for two years or up to 6,000 coffee brewings, whichever comes first. This warranty is in effect for the period and usage described above from the date of the first purchase and is limited to the United States of America. This warranty covers all defects in materials or workmanship (parts and labor) including free UPS ground transportation for both ways within the continental United States. For Hawaii and Alaska freight is not covered by this warranty. In case the machine cannot be repaired, JURA-CAPRESSO will replace your machine with the same model with the same or less usage. In case we cannot replace your machine with the same model we will replace it with a model of the same or higher retail value with the same or less usage. Usage is defined by the number of coffees the machine has made when sent for repair.

**TRANSPORT:** When sending the machine, use the original packing, the inner and outer cartons or use approximately 2" of bubble wrap and insert machine in a carton which will hold 40lbs. Any damage in transit is NOT covered by this warranty.

#### **THIS WARRANTY DOES NOT COVER:**

- Any machine NOT distributed by JURA-CAPRESSO within the United States.
- Any machine not purchased from an Authorized Jura-Cappresso Dealer. (Call our customer service department to check for authorized dealers).
- Any machine purchased through EBAY.
- Damage caused by accident, abuse, negligence, misuse, improper operation or failure to follow instructions contained in this manual.
- Any service or alteration performed by an unauthorized person, company or association.
- Damage caused by neglecting and omitting maintenance, cleaning and decalcifying cycles.
- Damage caused by use of instant coffee or any other ingredients not allowed in this product.

#### **Other limitations and exclusions:**

Any implied warranties including fitness for use and merchantability are limited in duration to the period of the express warranty set forth above and no person is authorized to assume for JURA-CAPRESSO any other liability in connection with the sale of the machine. JURA-CAPRESSO expressly disclaims liability for incidental and consequential damages caused by the machine. The terms "incidental damages" refer to the loss of the original purchasers time, loss of the use of the machine or other costs relating to the care and custody of the machine. The terms

"consequential damages" refer to the cost of repairing or replacing other property which is damaged when this machine does not work properly. Any loss of income is excluded. The remedies provided under this warranty are exclusive and in lieu of all others. This warranty gives you specific legal rights, and you may also have other rights which vary from state to state.

#### **24. FREE REPAIR SERVICE / EXTRA REPAIR COVERAGE**

Within the warranty period all repairs are free of charge including UPS ground transportation to and from our service facilities within the Continental United States. For Hawaii and Alaska freight is not covered by this warranty.

Within four weeks after your product registration you can purchase an extra 12 months of repair coverage. For details see the literature enclosed with this product.